



DRAFT TANZANIA STANDARD

Padlocks and padlock fittings – Specification

DRAFT FOR PUBLIC COMMENTS

TANZANIA BUREAU OF STANDARDS

This Tanzania Standard was published under the authority of the Board of Directors of Tanzania Bureau of Standards on 2021-XX-YY.

Tanzania Bureau of Standards (TBS) is the statutory national standards body for Tanzania established under the Standards Act No. 3 of 1975, repealed and replaced by the Standards Act No. 2 of 2009.

The Mechanical Engineering Divisional Standards Committee, under whose supervision this Tanzania Standard was prepared, consists of representatives from the following organizations:

College of Engineering and Technology, University of Dar es Salaam
National Institute of Transport
Mechanical Engineering Industries Development Agency
Ministry of Works
Weights and Measures Agency
Tanzania Industries Research Development Organization
National Development Corporation
ALAF Limited

The following organizations were directly represented on the Technical Committee entrusted with the preparation of this Tanzania Standard:

College of Engineering and Technology, University of Dar es Salaam
ALAF Limited
Dar es Salaam Institute of Technology
National Development Corporation
Tanzania Automotive Technology Centre
MM Integrated Steel Mills
Trans Auto Parts Company Limited

Tanzania Bureau of Standards P O Box 9524
Dar es Salaam
Tel: +255 (22) 2450206/2450949/2450298
Fax: +255 22 2450298
E-mail: info@tbs.go.tz

ISBN: 978-9987-11-368-2

Padlocks and padlock fittings – Specification

0 Foreword

Padlocks are portable locks used to protect against theft, vandalism, sabotage, espionage, unauthorized use, and harm. They are designed to protect against some degree of forced and surreptitious entry. The padlock and padlock fittings must have several important features to be effective. These features need to be standardized so as to meet and address all the factors mentioned above. In making sure that all performance requirements such as strength, security, corrosion resistivity are met, TBS come up with this Tanzania Standard TZS 1413: 2021, *Padlocks and padlock fittings – Specification and test methods*.

This Tanzania Standard has been prepared by the Metals and Structures Technical Committee under the supervision of the Mechanical Engineering Divisional Standards Committee.

For the purpose of deciding whether a particular requirement of this Tanzania Standard is complied with, the final value observed or calculated expressing the result of a measurement or test shall be rounded off in accordance with TZS 4 (see clause 2).

In preparation of this Tanzania Standard the assistance was drawn from:

BS EN 12320: 2012, *Building hardware – Padlocks and padlock fittings – Requirements and test methods*, published by BSI Standards Limited.

ASTM F883 – 13, *Standard Performance Specification for Padlocks*, published by American Society for Testing and Materials.

IS 15275:2003, *Padlocks – Specification*, published by Bureau of Indian Standards.

1 Scope

This Tanzania Standard specifies requirements, test methods and sampling of padlocks and padlock fittings used on buildings and general use. It covers performance and other requirements for dimension, strength, security, durability, material and corrosion of padlocks and padlock fittings.

The specifications cover environmental, operational and security requirements for padlocks. Included are function descriptions, cycle tests, operational tests, environmental tests, forcing tests, and surreptitious entry tests.

This specification describes and grades various levels of performance to provide users of the specification with criteria upon which to select suitable padlocks. Six levels of performance are described in this specification with Grade 1 the lowest and Grade 6 the highest.

Tests described are laboratory tests and although they simulate field conditions as to attacks or the environment, they do not duplicate these conditions. Tests described are repeatable in the laboratory.

2 Normative references

This Tanzania Standard incorporates by dated or undated reference, provisions from other publications. These normative references are cited at the appropriate places in the text and the publications are listed hereafter. For dated references, subsequent amendments to or revisions of any of these publications apply to this Tanzania Standard only when incorporated in it by amendment or revision. For undated references the latest edition of the publication referred to applies (including amendments).

ISO 1456, *Metallic and other inorganic coatings — Electrodeposited coatings of nickel, nickel plus chromium, copper plus nickel and of copper plus nickel plus chromium*

ISO 2081, Metallic and other inorganic coatings — Electroplated coatings of zinc with supplementary treatments on iron or steel

ISO 19598, Metallic coatings — Electroplated coatings of zinc and zinc alloys on iron or steel with supplementary Cr(VI)-free treatment

ISO 9227, Corrosion tests in artificial atmospheres — Salt spray tests

3 Terms and Definitions

For the purpose of this standard the following definitions shall apply:

3.1 acceptance testing

to assure by documented testing that a padlock meets specific tests of Specification as agreed to by the buyer and seller.

3.2 bump key

lock picking key with uniform steeples between cuts that is forced further into the lock via impact.

3.3 cam

lock or cylinder component which transfers the rotational motion of a key or cylinder plug to the bolt works of a lock.

3.4 case

housing or body of a lock or latch.

3.5 certified

to assure by documented testing that a padlock meets all test requirements appropriate to its grading.

3.6 clevis

fastener attached to a padlock case or shackle for connection of a chain, designed to prevent displacement of a padlock.

3.7 cylinder

complete operating unit which usually consists of the plug, shell, tumblers, springs, plug retainer, a cam/tailpiece or other actuating device, and all other necessary operating parts.

3.8 cylinder bitting

group of numbers that represent the bitting of a key or the tumblers, or both, of a lock or cylinder.

3.9 decode

to determine a key combination by physical measurement of a key or cylinder parts, or both.

3.10 heel

part of a padlock shackle that normally is retained in the case when in the unlocked position.

3.11 impression technique

means of fitting a key directly to a locked cylinder by manipulating a blank in the keyway and cutting the blank where the tumblers have made marks.

3.12 keyway

opening in a lock or cylinder that is shaped to accept a key bit or blade of a proper configuration.

3.13 lock bumping

picking technique that utilizes a configured key forcefully impacted into the keyway.

3.14 padlock

detachable and portable lock with a shackle that locks into its case. Components performing the same purpose of a shackle but differing in design are sometimes used instead of a shackle.

3.15 pick

to manipulate tumblers in a keyed lock mechanism through the keyway, without obvious damage, by means other than the specifically designed key.

3.16 plug

part of a cylinder which contains the keyway, with tumbler chambers usually corresponding to those in the cylinder shell.

3.17 plug retainer

cylinder component that secures the plug in the shell.

3.18 pull bump key

lock picking key that must be pulled from the lock one space position between impacts.

3.19 push bump key

lock picking key that centers itself after each impact.

3.20 rap

to unlock a padlock shackle from its case by striking the case in order to disengage the locking mechanism.

3.21 removable cylinder

cylinder that can be removed from a locking device by a key or tool, or both.

3.22 shackle

part of a padlock that passes through an opening in an object or fits around an object and is ultimately locked into the case.

3.23 shroud

material on a padlock body specifically added to protect the shackle from physical attack.

3.24 tailpiece

actuator attached to or part of the rear of the cylinder.

3.25 toe

part of a padlock shackle that is normally released from the case in the unlocked position.

3.26 tumbler

movable obstruction of varying size and configuration in a lock or cylinder that makes direct contact with the key or another tumbler and prevents an incorrect key or torqueing device from activating the lock or other mechanism.

4 Requirements

4.1 Workmanship and finish

The method of manufacturing of padlocks and its components is left to the manufacturer; however, it shall meet the requirements laid down in this standard. All components of the padlocks and keys shall be finished smooth to minimize frictional resistance in their working.

The body of the padlock, if required, shall be suitably painted/plated. The shackle and keys for brass padlocks shall, however be finished bright.

Steel components shall be suitably protected to resist corrosion.

4.2 Dimensions and shapes

4.2.1 Padlocks having sizes other than those specified in Table 1 may also be permitted as agreed to between the purchaser and the supplier, but the other provisions in this standard will be generally adhered to. The typical shape and design of padlocks and their designs are indicated for information in Annex A.

Table 1: Dimensions of Lock and Shackle

Nominal Size of Lock, mm	Minimum Shackle Diameter, mm
25	4
30	4
40	5
45	6
50	6
55	8
60	8
65	9
70	10
75	11
85	12
90	12

Note: The tolerances for size of lock shall be ± 2 mm.

4.3 Classification

4.3.1 General

Classification shall be in form of a four digit code as shown below:

Table 2: Classification

1	2	3	4
Category of use	Durability	Corrosion resistance	Security

4.3.2 Category of use (first digit)

Grade 1: for use by people with high incentive to exercise care and with small chance of misuse.

4.3.3 Durability (second digit)

Grade 0: no requirements.

Grade 1: 10,000 cycles.

4.3.4 Corrosion resistance (third digit)

Padlocks and padlock fittings shall be classified in six grades.

4.3.5 Security (fourth digit)

Padlocks and padlock fittings shall be classified in security grades 1 to 6, where 6 is the highest.

Example

1	1	3	5
---	---	---	---

Box 1: Grade 1

Box 2: Durability grade (1)

Box 3: Corrosion grade (3)

Box 4: Security grade (5)

4.4 Material requirements

4.4.1 The components of the various types of padlocks shall be manufactured from the recommended materials in Tables 3, 4, 5 and 6 and the manufacturer may select suitable materials for the manufacture of padlock.

Table 3: Recommended Materials for Various Components of Padlocks (In General)

S/No.	Component	Recommended Material
1	Key	Brass sheet or Steel sheet or Stainless steel or Nickel silver
2	Spring	Spring steel wire or Phosphor bronze wire
3	Shackle	Bright bars or Stainless steel bars and flats or Stainless steel wire rod
4	Case/Body	Steel sheet or Stainless steel sheet or Brass sheet

Table 4: Recommended Materials for Various Components of Disc Tumbler Padlock

S/No.	Component	Recommended Material
1	Body and plug	Zinc base alloy Die castings or Aluminum alloy or Leaded brass or Nylon, delrin, Polycarbonate or Free cutting leaded brass
2	Disc tumbler	Brass sheet or Steel sheet or Aluminum alloy

Table 5: Recommended Materials for Various Components of Pin Tumbler Padlock

S/No.	Component	Recommended Material
1	Body and plug	Zinc base alloy die castings or Aluminium alloy or Brass gravity die casting or Free cutting leaded brass
2	Cylinder	Zinc base alloy die castings or Brass gravity die casting or Brass rod
3	Pin tumbler	Brass wire or Nickel silver rods

Table 6: Recommended Materials for Various Components of Lever Padlock

S/No.	Component	Recommended Material
1	Body and plug	Zinc base alloy die castings or Aluminium alloy or Leaded brass or Nylon, delrin, polycarbonate, etc or Brass sheet
2	Lever	Brass sheet or Steel sheet or Aluminium alloy sheet
3	Rivet	Mild steel wire

4.4.2 Steel components shall be suitably protected to resist corrosion. The electroplated coating of nickel plus chromium, zinc on iron and steel or brass plating wherever specified, shall be done in accordance with Grade C of ISO 1456, Grade B of ISO 2081 and Class A of ISO 19598 respectively. The electroplated coating of copper plus nickel plus chromium shall be done in accordance with ISO 1456.

4.5 Performance requirements

4.5.1 Padlocks shall meet all the required values set forth in Tables 7-10 as applicable in order to qualify for the applicable grade level of 1 through 6.

4.5.2 A failure of any one padlock in the forcing or cycle tests constitutes a failure of the complete test. See 5.3 for acceptance criteria for surreptitious entry tests.

4.5.3 Successfully passing the Salt Spray Test and Environmental Tests, or both, for any one model constitutes acceptance for all sizes in the model tested, providing the materials used for all sizes are the same.

4.5.4 Users may want padlocks exceeding the required criteria of one or more of the tests in a given grade level. Manufacturers may identify the grade level and levels of performance exceeding the requirements for that class (see Annex B).

4.5.5 Cylinder picking, impressioning, rapping, decoding, and shackle shimming are described in this specification. Since the skill of the person doing the testing has a direct bearing on the resulting times of the tests, one of each test shall be conducted by a minimum of three different persons having experience of not less than three years of approximately the same skill level and the results averaged for determining relative levels of performance.

4.5.6 Key bumping is a subjective test to be conducted using bump keys designed for the lock or cylinder being tested and an impact device as outlined in clause 6.

4.5.7 Tolerances:

4.5.7.1 Fixture Tolerances—All tolerances shall follow standard machining practices unless otherwise specified.

4.5.7.2 Test Set up Tolerances:

4.5.7.2.1 Force: 0.5 % of working range.

4.5.7.2.2 Height: 63 mm.

4.5.7.2.3 Torque: 4.0 % of reading.

4.5.7.2.4 Weight: 610 g.

4.5.8 Temperature—All tests shall be conducted between 16° and 27°C (61° and 81°F).

4.5.9 Test Reports—All test reports shall be dated.

Table 7: Cycle Tests Required Values

Cycle Tests	Grades					
	K1	K2	K3	K4	K5	K6
Keyed Padlocks (x 1000)	1	10	25	50	75	100
Force to Insert Key Maximum (all Grades), N	12 N					
Force to Extract Key Maximum (all Grades), N	12 N					
Torque to Rotate Cylinder Plug Maximum, Nm (Newton Metres)	0.17	0.17	0.13	0.13	0.08	0.08
Combination Padlocks (x 1000)	1	10	25	50	75	100

Table 8: Required Values for Corrosion and Environmental Tests

Corrosion Testing:	Grades					
	C1	C2	C3	C4	C5	C6
Salt spray cumulative time (h)	120	144	168	192	216	240
Weathering Testing:	W1	W2	W3	W4	W5	W6
Salt spray (fog) cumulative time (h)	96	192	288	384	480	576
UV light/condensed moisture condensation cumulative time (h)	16	32	48	64	80	96
UV light cumulative time (h)	32	64	96	128	160	192
Exposure totals cumulative time (h)	144	288	432	576	720	864

Table 9: Surreptitious Entry Tests Required Values

Surreptitious Entry Tests	Grades					
	1 (S1)	2 (S2)	3 (S3)	4 (S4)	5 (S5)	6 (S6)
Picking or Manipulation, min	1/2	1	2	4	8	15
Bump Key Attack, min	2 1/2	5	7 1/2	10	12 1/2	15
Impressioning or Decoding min	N/A	N/A	2	4	8	15
Shackle Shimming Test min	1/2	1	2	4	8	15
Drilling and Shimming min	N/A	N/A	N/A	4	8	15
Rapping min	N/A	N/A	2	4	8	15

Table 10: Forcing Tests Required Values

Forcing Tests	Units	Grades					
		1 (F1)	2 (F2)	3 (F3)	4 (F4)	5 (F5)	6 (F6)
Tensile Force	newtons	1000	2500	5000	9000	20000	40000
Shock/Impact test blows		5	5	5	5	5	5
Shock/Impact test weights	kilograms	1	2	3	4	5	6
Shock/Impact test heights	meters	1	1	1	1	1	1
Plug pull test	newtons	1000	1500	2000	3000	6000	12000
Plug torque test	newton-meters	10	15	20	25	30	35
Shackle cutting force test	newtons	4450	9000	13500	18000	31000	45000
Resistance to sawing of padlock body, shackle and staple	minutes	-	-	-	2	4	8

5 Test Methods

5.1 Durability test/Cycle Test

5.1.1 Keyed Padlocks:

Prior to conducting the cycle test, insert key into each padlock cylinder 25 times and manually rotate both clockwise and counter clockwise (if possible, otherwise in the direction of opening) after each insertion.

5.1.1.1 Operate the required number of cycles at a rate not to exceed 10 cycles/min. Lubrication shall not be added during the test.

5.1.1.2 At the beginning and the end of the cycle test, cylinders shall meet the operational tests. The required values for these tests are expressed in Table 7 of this specification.

5.1.1.3 Failure occurs if the test cannot be completed, the padlock does not operate at the conclusion of the test, the key breaks, or the requirements of 10.1.1.2 are not attained.

5.1.2 Non-Key Retaining Padlocks

In a test fixture which will horizontally hold the padlock and mechanically operate the key, activate through a cycle consisting of the following:

5.1.2.1 Fully inserting the key in the keyway.

5.1.2.2 Rotating the key and cylinder plug the necessary number of degrees to open the padlock either clockwise or counter clockwise.

5.1.2.3 Allowing the shackle to extend, if spring loaded, or not, moving the shackle to its full extension.

5.1.2.4 Retracting the key from the plug until the key tip no longer touches the front tumbler.

5.1.2.5 Reengaging the shackle to the locked position.

5.1.3 Key Retaining Padlocks

In a test fixture that will hold the padlock horizontally and mechanically operate the key, activate through a cycle consisting of the following:

5.1.3.1 Fully inserting the key in the keyway.

5.1.3.2 Rotating the key and plug the amount and direction necessary to open the padlock.

5.1.3.3 Allowing the shackle to extend, if spring loaded, or if not, moving the shackle to its full extension.

5.1.3.4 Reengaging the shackle to the locked position. Rotate key in plug to home position.

5.1.3.5 Retracting the key from the plug until the key tip no longer touches the front tumbler.

5.1.2 Combination Padlock

Cycle single dial and multiple disk padlocks in alternate directions for the required number of cycles at a rate not to exceed 10 cycles per minute, with no more than a 2 s dwell. One cycle is equal to the number of revolutions necessary to upset all combination disks. At the conclusion of the test, failure occurs if the test cannot be completed or the padlock does not operate at the conclusion of the test. Lubrication shall not be added during the test.

5.2 Corrosion and Environmental Tests

5.2.1 Corrosion Resistant—Salt Spray Test

After an exposure of the required number of hours according to Table 8, padlocks shall operate. Test one padlock, suspended by nylon cord in the vertical upright position. Conduct the test and clean for 10 min in accordance with ISO 9227. Failure of any lock to unlock and relock within 1 min indicates failure.

5.2.2 Weathering-Corrosion Environment Test

Three padlocks are exposed to sequential cycles of salt spray and condensation-ultra violet radiation. At the conclusion of the condensation-ultra violet radiation phase of the test, the padlocks are unlocked and relocked to check operation.

The number of exposure hours for a specific grade is shown in Table 8.

Failure of any lock to unlock and relock within 1 min indicates failure.

The padlocks must pass the previous grade level test successfully before being tested to the next grade level.

5.3 Surreptitious Entry Tests (see Table 9)

5.3.1 Picking or Manipulating Test

5.3.1.1 Cylinders in padlocks shall resist picking (see 4.5.5) for the required time. Combination padlocks shall resist manual manipulation (see 4.5.5) for the required time.

5.3.1.2 Cylinders or padlocks submitted for test containing pin tumblers shall be loaded using one each of the three or four mid-range bittings available unless such a combination would not normally be supplied as a stock product. Cylinders in padlocks containing other tumbler elements shall be loaded using maximum ranges. If lock design and cylinders used are the same in several different sizes of padlocks submitted for testing, only a total of five samples of any size or sizes need to be tested.

5.3.1.3 The tools used for this test shall be manual manipulating tools required by the operator, providing no visible marks are left detectable by the unaided eye.

5.3.2 Cylinder Impressioning and Decoding Tests

5.3.2.1 Cylinders shall resist successful impressioning and decoding (see 4.5.5) for the required time.

5.3.2.2 Padlocks with cylinders submitted for test shall be loaded in accordance with 5.3.1.2.

5.3.3 Shackle Shimming Test

Insert any shim stock selected (see 4.5.5) that can be inserted in the clearance between the shackle and the case in either or both of the case shackle holes of a locked padlock and manipulate for the required time.

5.3.4 Cylinder Drilling and Shimming Test

5.3.4.1 Use hand-held tools.

5.3.4.2 Load cylinders in accordance with 5.3.1.2.

5.3.4.3 Cylinders in locked padlocks hanging from a hasp shall resist drilling and shimming for the required time. Results of the drilling test shall not be obvious to the unaided eye.

5.3.5 Rap Test

5.3.5.1 Use hand-held tools.

5.3.5.2 Padlocks shall resist successful rapping on the cylinder and case (see 4.5.5) for the required time.

5.3.6 Key Bumping Test—The testing person must change the order of testing for 5.3.6.1 and 5.3.6.2 to use the most likely successful bumping attack first.

5.3.6.1 A lock or cylinder not previously bump tested by the locksmith is permitted to be mounted in a block if the testing person prefers that method and have the prepared pull bump key inserted. A prepared pull bump key is permitted to have a hole drilled in the bow for mounting a weight bar.

5.3.6.2 A lock or cylinder bump tested per 5.3.6.1 is permitted to be mounted in a block if the testing person prefers that method and have the prepared push bump key inserted. A prepared push bump key is permitted to have a hole drilled in the bow for mounting a weight bar.

5.3.6.3 Impacts with the impact device shall be by hand using a rapping motion which ensures that the impact device applies force to the bump key a single time and does not allow bouncing impact of the impact device.

5.3.6.4 Impacts to the key shall be performed at a minimum rate of 4 per minute. Any accelerated rate of impact is permitted to be used during the test to achieve the quantity of impacts required by the stated minimum rate/time requirement for a given grade level, that is, 10 impacts in 2.5 min by each type of bump key without operation = Grade 1, or 10 impacts by each type of bump key in less than 2.5 min without operation = Grade 1.

5.3.6.5 The torque applied to the bump key during the impact testing shall be no less or no greater than the testing person has found optimum from past experience.

5.3.6.6 If the cylinder or lock is not operated by the bump key within 10 impact cycles of either type of bump key, the lock is classed as Grade 1. Locks or cylinders that are operated by either type of bump key in 10 or less impacts will be qualified as having Grade zero bump resistance.

5.3.6.7 The test described in 5.3.6.4 – 5.3.6.6 shall be repeated through 10 complete impact cycles with each type bump key for each Grade level from 2 through 6 or until operated by a bump key. A cylinder or lock that is operated by either type of bump key on the 11th through 20th cycle will be qualified as Grade 1, 21st through 30th = Grade 2, 31st through 40th = Grade 3, 41st through 50th = Grade 4, 51st through 60th = Grade 5. Any cylinder or lock that resists operating for a total of 60 impacts by each type of bump key shall be qualified as Grade 6.

5.3.6.8 The test shall be repeated for each of the remaining cylinders.

5.3.6.9 At the conclusion of testing by each locksmith the seventh cut key shall be used to verify that the lock or cylinder still functions.

5.3.6.10 Failure of the lock or cylinder to function does not constitute failure of the testing since it provides a detection method of a bumping attempt.

5.3.6.11 A lock or cylinder which captures the bump key to prevent an unlocking motion using a bump key shall be classed as Grade 6.

5.4 Forcing Tests (see Table 10)

5.4.1 Tensile Test (Does not apply if test cannot be performed) (see 6.1)

Support the locked padlock in a fixture bearing against the top surface of the case without interfering with the shackle or giving support through the top of the case to the shackle retaining mechanism. Apply the required force slowly along the vertical centerline of the padlock in a direct and equal tension on each leg of the shackle. Failure occurs if the padlock opens.

5.4.2 Shock Test

Using the impactor (6.2) drop the weight the required number of times on the top of the locked padlock case. Failure occurs if the padlock opens.

5.4.3 Plug Pulling Test

Drill the keyway with a No. 20, 4 mm (0.161 in.) diameter drill and insert a Type AB No. 12 screw at least 19 mm (0.75 in.) deep. Apply the required tension (6.1) axially between the case and the installed screw. Failure occurs if the cylinder plug or cylinder assembly completely separates from the case, or if the padlock can be opened by manipulation with a screwdriver at the conclusion of the test.

NOTE 1: Some cylinders are of a configuration such that a different attachment may be needed in order to apply the required loads.

5.4.4 Plug Torque Test

5.4.4.1 Install the padlock in a rigid fixture such as a vice to support it firmly but not restrict free rotation of the plug in the cylinder.

5.4.4.2 Insert a blade type tool into the keyway, so that a torque load can be applied to the plug. Failure occurs if the padlock opens.

5.4.5 Shackle Cutting Test (Does not apply if test cannot be performed)

Shackles shall withstand cutting through when 2 shearing blades made of a steel hardened to a minimum hardness of Rc 50, are used in conjunction with the blade positioning holder, is placed in a tensile loading device (6.1) having a compression load capability and compressed with the required force. See Annex B for details. Failure occurs if the shackle is cut through.

5.4.6 Sawing Test

Mount the padlock on to a suitable test rig for use with a sawing machine as shown in Fig. B.10. Saw blades used shall be bi-metal saw blades with 24 TPI tensioned to 1 kN. The sawing machine shall make 60 complete 165 mm stroke cycles per minute, with an applied load of 90N. Do not use any coolant during the test. Sawing shall be carried out for vulnerable areas for time t (Table 10).

6. Preparation of Apparatus

6.1 Tensile Loading Device

Provide a tensile loading device having a load and force measuring capacity of 44 500 N (10000lbf).

6.2 Shock Impactor:

6.2.1 Provide a fixture as illustrated in Annex B which allows the weights described in (6.2.2) to be properly guided to strike the anvil rod which will be placed in direct contact with the top surface of a padlock using the mounting block described in (6.2.3).

6.2.2 Make a set of weights as shown in Annex B, with a central hole in each that allows the weight selected to free fall and strike the top surface of the anvil rod.

6.2.3 Make a mounting block that will support the specimen on the mounting block when being subjected to the required shock load (see Table 10).

6.3 Key Bumping:

6.3.1 Each locksmith performing the test shall use two of the supplied keys to fabricate his own pull bump key and push bump key.

6.3.2 Both a pull bump key and a push bump key shall be used to test a lock or cylinder for bump resistance by each of three locksmiths.

6.3.2.1 A torque bar is permitted to be used if the test person prefers that method.

6.3.2.2 A single impact cycle consists of having a bump key fully inserted into the keyway and withdrawing it one cut position for the pull type, inserting the key fully into the keyway and then releasing it to allow the pins to center it for the push type, impacting the end of the key to drive it fully into the keyway while torque is applied. If the cylinder or lock operates after the impact, it failed the test at that cycle and shall be given the appropriate grade level for the last cycle that did not accomplish operation. If it did not operate, a new cycle shall be achieved until the lock or cylinder reaches Grade 6.

6.3.3 Provide various mounting blocks for locks or cylinders as required by the test person if rigid mounting is preferred.

6.3.4 The impact device shall be a non-metal instrument with a weight not to exceed 0.25 lb (113.4g).

7 Sampling and Inspection

In any consignment, all the locks of the same type, same size, and manufactured from the similar materials under similar conditions of manufacture shall be grouped together to constitute a lot.

For ascertaining the conformity of the lot to the requirements of this standard, the sample of padlocks shall be and tested separately for each lot.

The number of sample locks to be selected at random from a lot shall depend upon the size of the lot and shall be in accordance with Table 11. The padlocks in the samples shall be selected at random from the lot.

In case padlocks are packed in boxes, 20 percent of the boxes, subject to a minimum of two, shall be opened and equal number of padlocks shall be taken from each box so as to constitute the required sample size.

The padlocks selected shall be inspected for dimensions, workmanship and finish. The lot shall be considered as conforming to these requirements if the number of padlocks failing in any one or more of the requirements does not exceed the permissible number of defective padlocks given in Table 11.

Table 11: Sample Size and Criteria for Conformity

S/No.	Lot Size (No. of Locks in the Lot)	Dimensions, Workmanship and Finish		Material and Performance Test	
		Sample Size	Permissible No. of Defective Padlocks	Sub-sample	Permissible No. of Defective Padlocks
1	Up to 50	8	0	2	0
2	51 to 150	13	0	2	0
3	151 to 300	20	0	2	0
4	301 to 500	32	1	3	0
5	501 to 1000	50	2	5	0
6	1001 to 3000	80	3	10	0
7	3001 to 10000	125	5	15	1
8	10001 and above	200	7	20	2

8 Packaging and Marking

7.1 Each padlock with its keys shall be packed in a moisture proof paper or polyethylene bag, or as agreed to between the purchaser and the supplier.

7.2 Each package of padlocks shall be marked with the following information:

- a) manufacturer's name or initials or trademark;
- b) batch number;
- c) classification and size of the padlock;
- d) country of origin;

7.3 Each padlock shall be marked with the following information:

- a) manufacturer's name or initials or trademark;
- b) batch number;
- c) classification and size of the padlock;

DRAFT FOR PUBLIC COMMENTS

ANNEX A

(Informative)

SHAPE

A1.1 Padlock Shape

A1.1.1 The typical shape and design of padlocks and their designs may also be made as per manufacturer's patent illustrative and for guidance only. Other shapes and designs may also be made as per manufacturer's patent or as agreed to between the purchaser and the supplier.

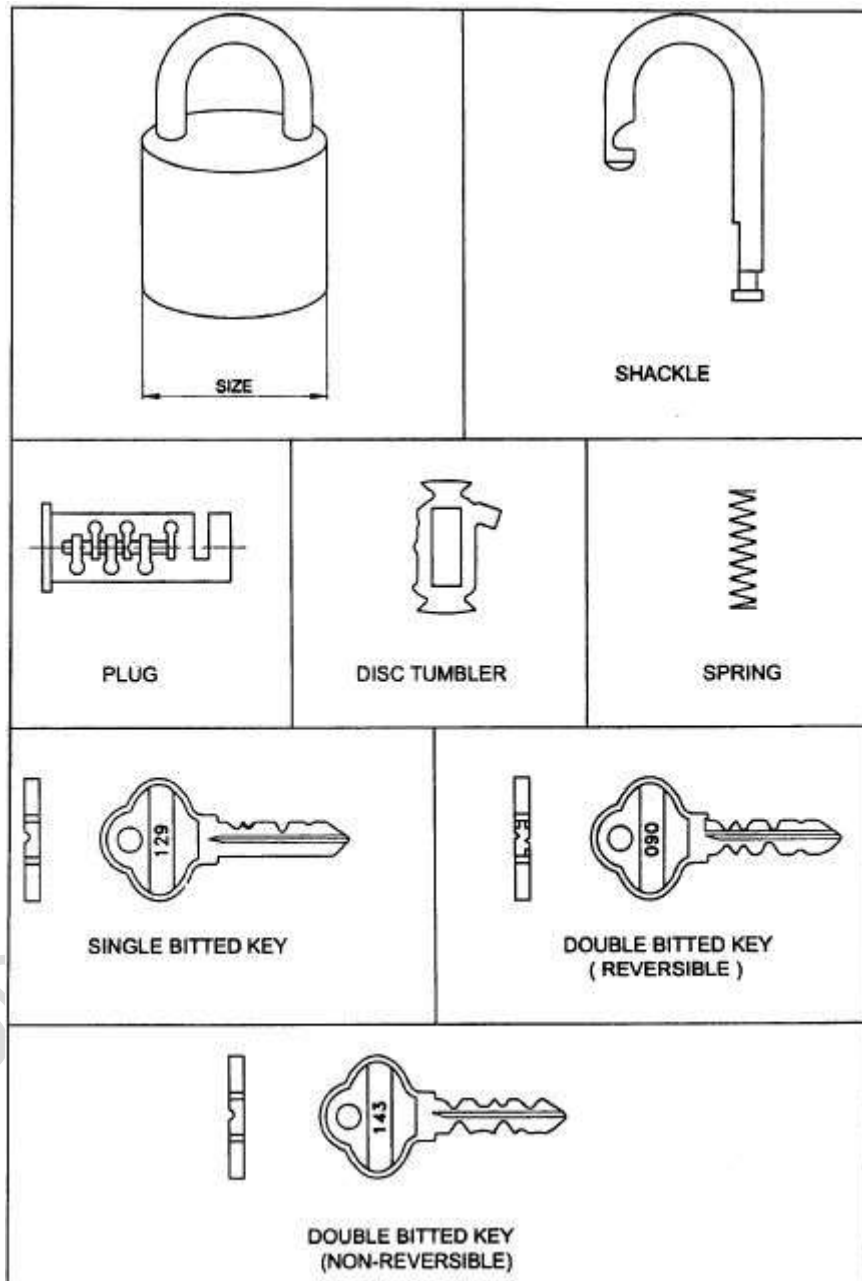

Figure 1: Disc Tumbler Padlock

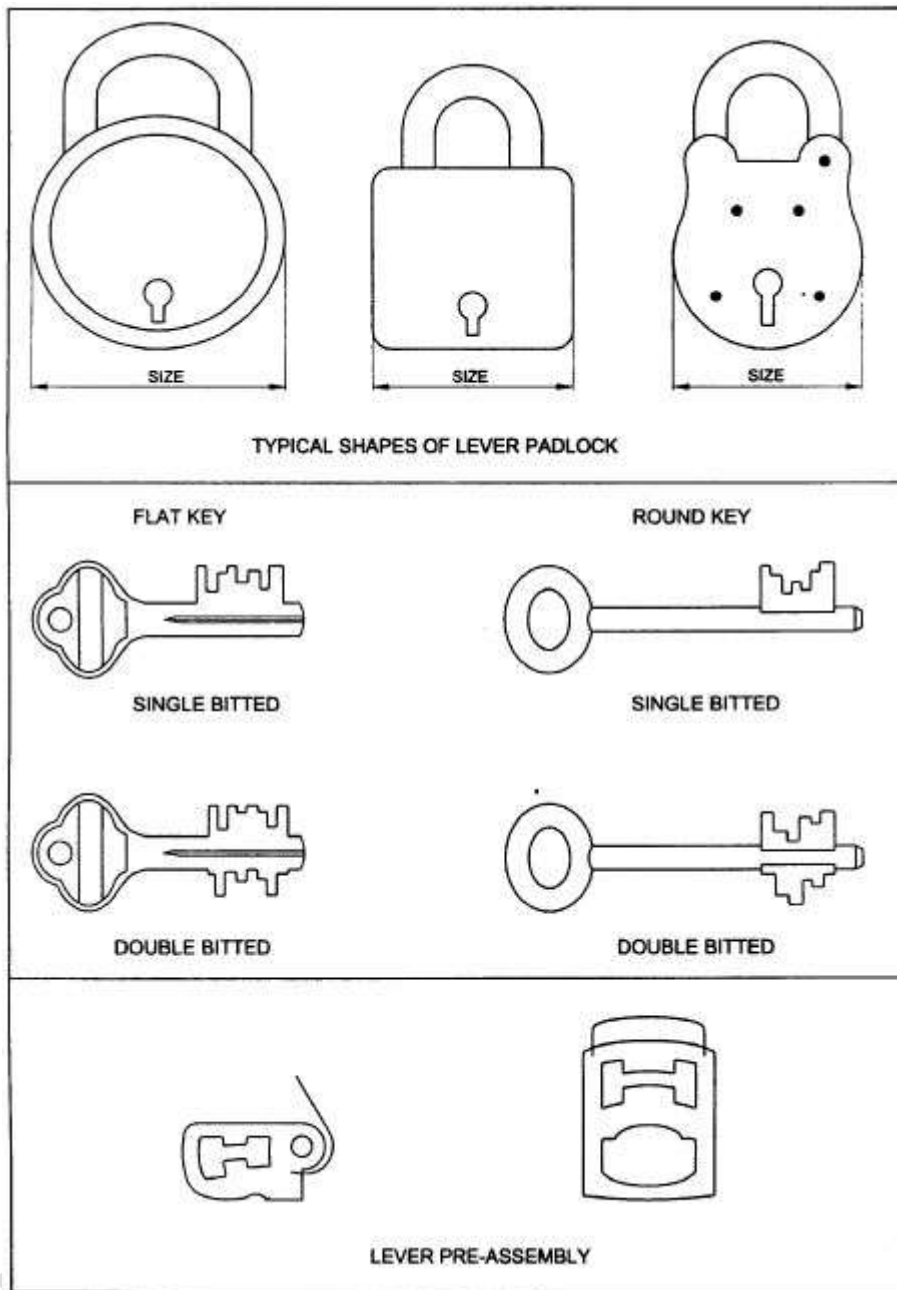

Figure 2: Lever Padlock

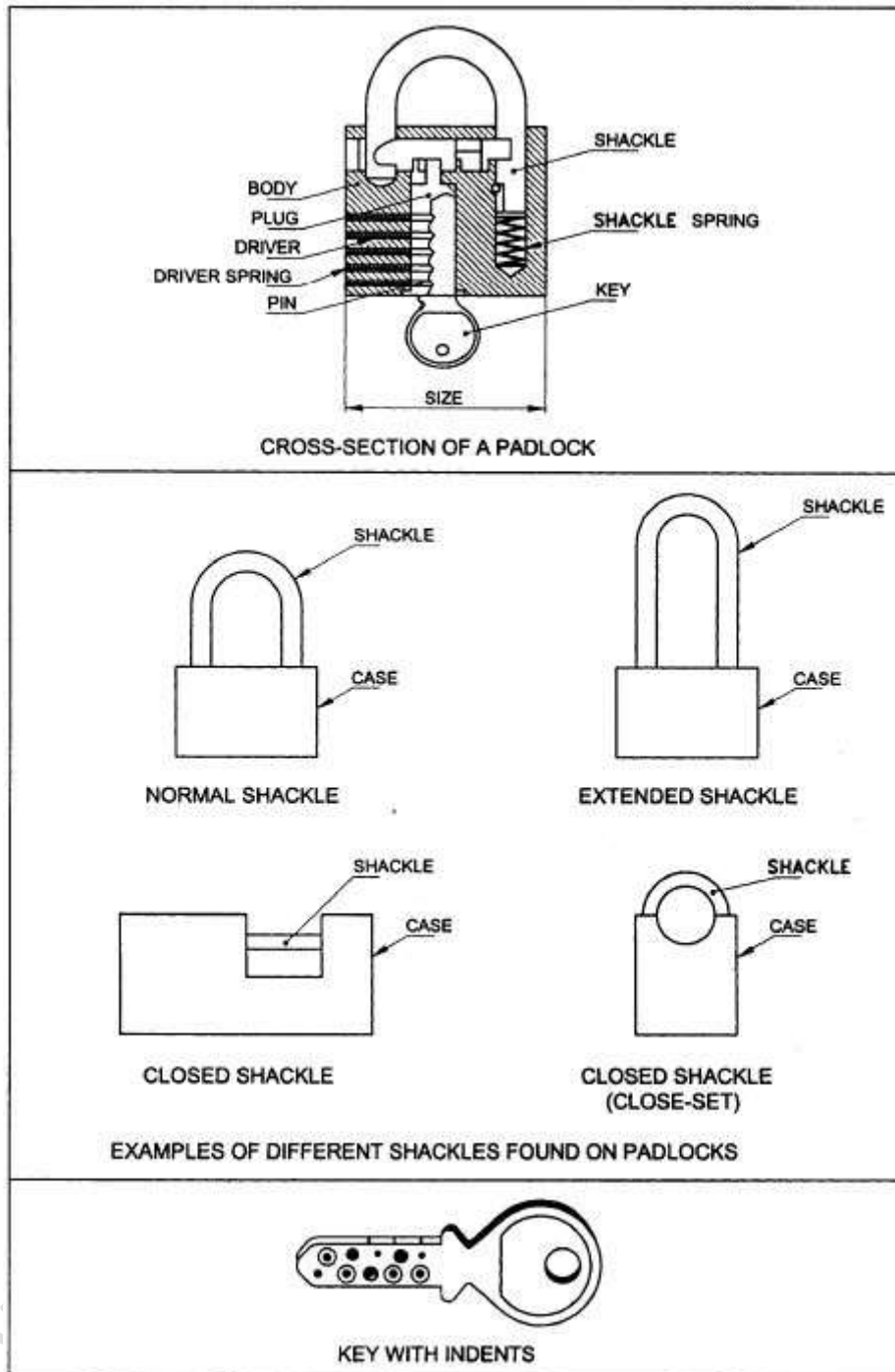

Figure 3: Pin Tumbler Padlock

ANNEX B
(Informative)
USER GUIDE

B1.1 Padlock Class Rating

B1.1.1 Padlocks meeting all the requirements of one of the Grades 1 through 6 shall be so rated.

B1.1.2 A padlock complying with one of the grades may exceed the requirements for that grade in the surreptitious entry test category or the forcing test category.

B1.1.3 A rating beyond 1 through 6 may be used by some manufacturers. For example, a padlock designated as Grade 3 may also have the parenthetical designation (F5S3). This would mean the padlock met the requirements for forcing test of Grade 5. Users of padlocks not overly concerned with surreptitious entry attack but wanting relatively high resistance to forcing would find such a padlock more useful than one rated Grade 3.

B1.1.4 The environmental tests listed in Table 4 are optional tests to be specified as needed by users of this standard. Taking into account the manner of padlock class rating as explained in

B1.1.1 – B1.1.3, combining requirements of forcing tests, surreptitious entry tests and environmental tests in varying grade levels for each category can result in specifying padlocks that do not exist. If the product desired is not readily related to a known padlock, individual manufacturers should be consulted.

B1.2 Options

B1.2.1 Under the function description, several optional features are described, including one for corrosion resistant criteria for padlocks used in an exterior or corrosive environment, one for nonferrous shackles used in situations where it is desirable for the shackle to be easily severed, one for those wishing a removable core feature, and others.

B1.2.2 These should be specified by indicating the function required with optional feature(s) desired.

B1.3 Chains

B1.3.1 If chains attached to the padlock are required, they must be so specified.

B1.4 Keys

B1.4.1 Two keys are customarily furnished with each padlock. If more or less are required, they must be so specified.

B1.5 Hasps

B1.5.1 Hasps are not addressed in this standard. The strength and fastening system of a hasp must be compatible with the grade of padlock in order to maintain the integrity of the locking system.

B1.6 Sizes

B1.6.1 Padlocks are generally sized according to the width of the case. As this width increases, the diameter of the shackle and the vertical and horizontal clearance between the shackle and the case increases. As the diameter of the shackle gets larger, its resistance to cutting attack because of greater mass becomes higher. Consequently, the same series of padlocks may have a low grade rating in a small size and an increasingly higher rating in subsequently larger sizes.

B1.7 Safe Key or Combination Changes

B1.7.1 Safe key or combination changes (those that do not interchange) are not unlimited and vary according to the number of tumblers in a cylinder or a combination mechanism. While this is not a function of the security of a single lock under this Standard, it becomes important in a system

incorporating many locks which have different keys or combinations for each lock. Anyone using this standard for procurement purposes must specify the number of safe changes required.

B1.7.2 Unless unique methods are used which are generally proprietary, any simple 6 pin master keyed system is limited to approximately 4000 safe key changes. If a relatively high security system is wanted and the system is still to be master keyed, safe changes are reduced to about 1000. If a 4 or 5 pin tumbler system is used, the safe key changes are again substantially reduced.

B1.7.3 No master key at all is best for achieving the goal of higher security, but may be inappropriate for efficient administration of the system.

B1.7.4 If requirements appear to be complex, individual specialists or manufacturers should be consulted.

B1.8 Tests

B1.8.1 The forcing tests included in this standard were devised so as to be accurately repeatable in a laboratory environment. The nature of the forces and loads imposed are intended to encourage the production of a padlock which will withstand a balanced variety of attacks. Criteria selected is based on guarding against known attack methods employed with the greatest frequency. Users of this standard with special needs may wish to impose additional cutting or forcing tests.

DRAFT FOR PUBLIC COMMENTS

ANNEX B
(Normative)

Test Rig Illustrations

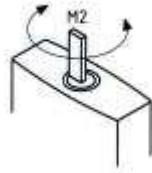
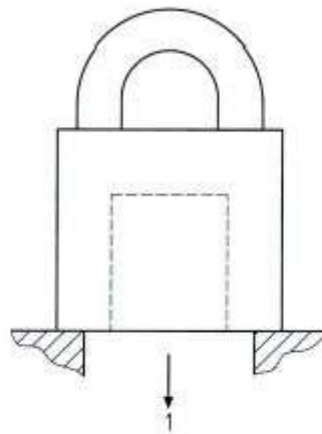
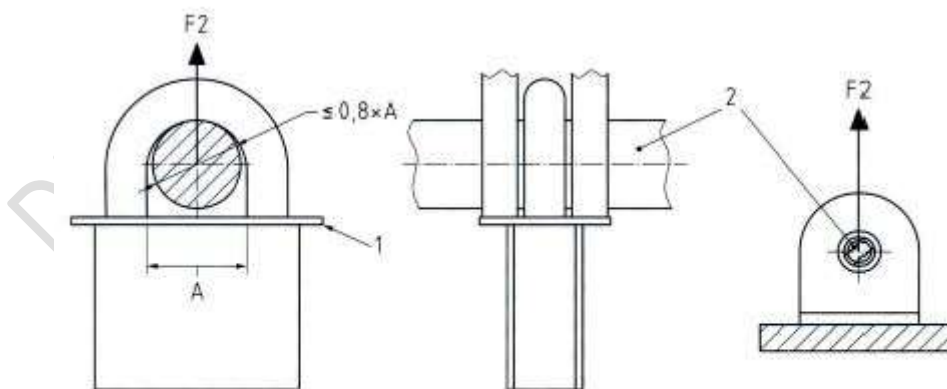

Figure B.1: Cylinder plug or locking mechanism torque test



Key
1 F1 = pull

Figure B.2: Cylinder locking mechanism Actual Pull Test



Key
1 Clamping device
2 Drawing punch

Figure B.3: Shackle/Staple Pulling Test

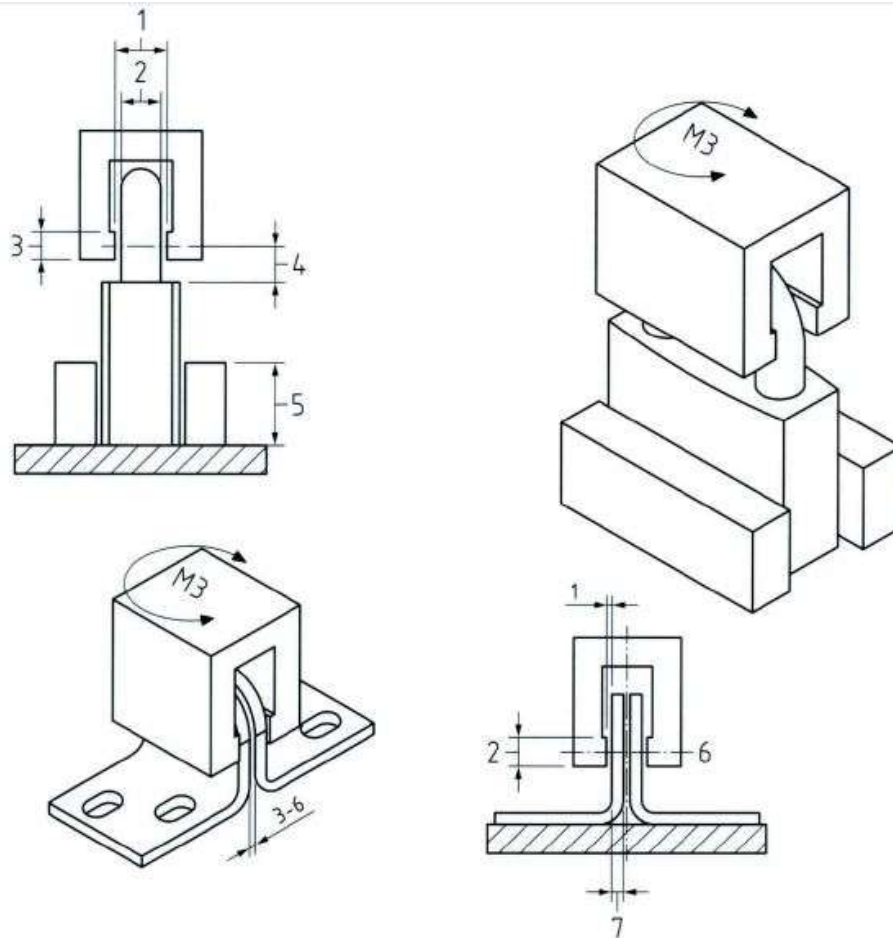

Key

- | | | | |
|---|--|---|-----------------------------------|
| 1 | $D + 2\text{mm}$ | 5 | $\frac{1}{2}$ padlock body height |
| 2 | D | 6 | Shackle hole D in staple |
| 3 | Shackle diameter, D | 7 | r |
| 4 | $\frac{1}{2}$ internal shackle height up to maximum of 25 mm | | |

Figure B.4: Shackle/Staple Twisting Test

DRAFT

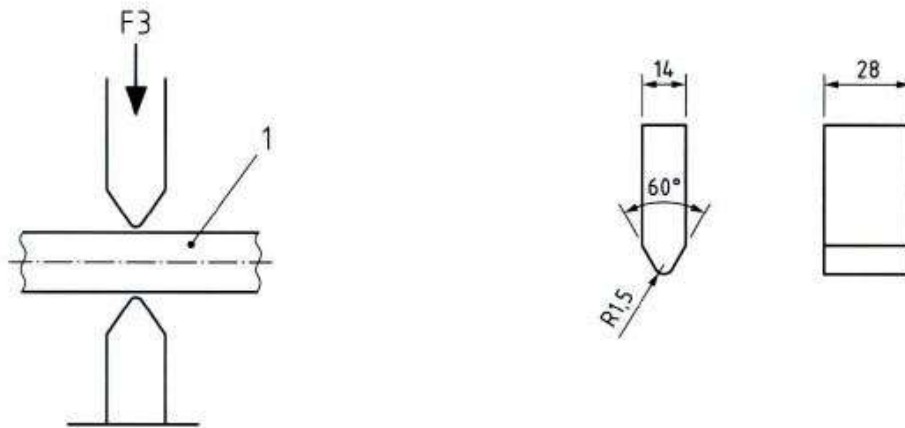

Key

- 1 Exposed section of shackle / staple

Figure B.5: Shackle/Staple Cutting Test

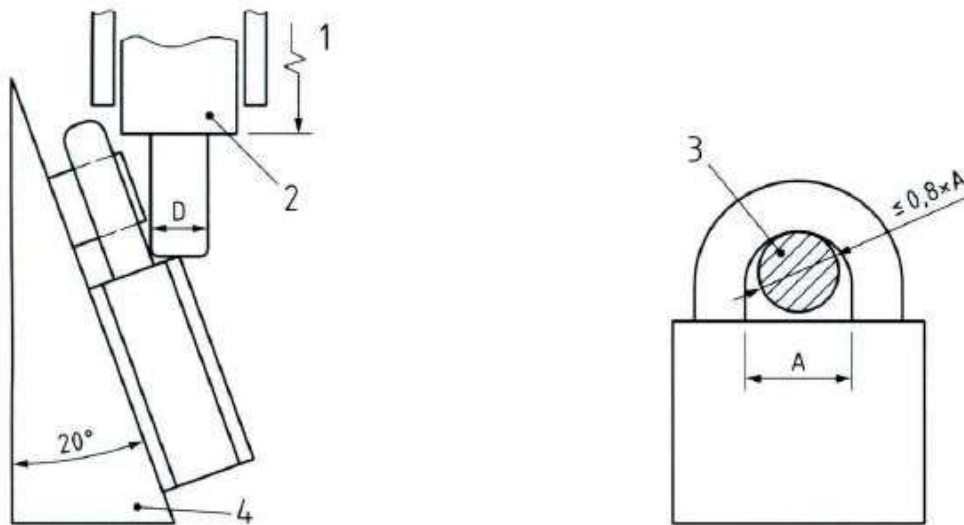

Key

- 1 Drop height h
- 2 Steel mass M (dropped five times)
- 3 Steel hanging device
- 4 Rigid steel structure

Figure B.6: Impact Test on Padlock Body

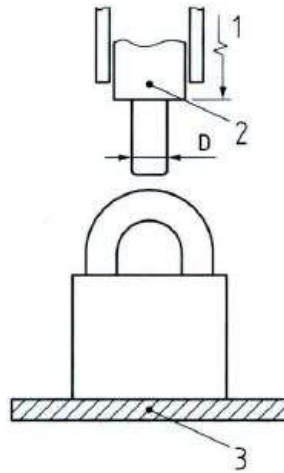

Key

- 1 Drop height h
- 2 Steel mass m (dropped five times)
- 3 Flat solid bed of steel

Figure B.7: Impact Test on Padlock Shackle

DRAFT FOR PUBLICATION

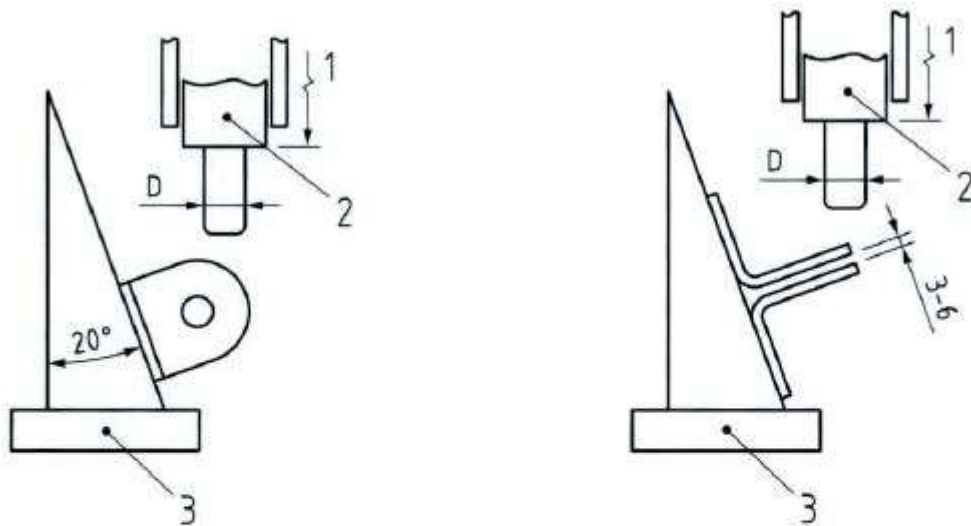

Key

- 1 Drop height h
- 2 Steel mass m (dropped five times)
- 3 Rigid steel structure

Figure B.8: Impact test on Staple

DRAFT FOR PUBLIC

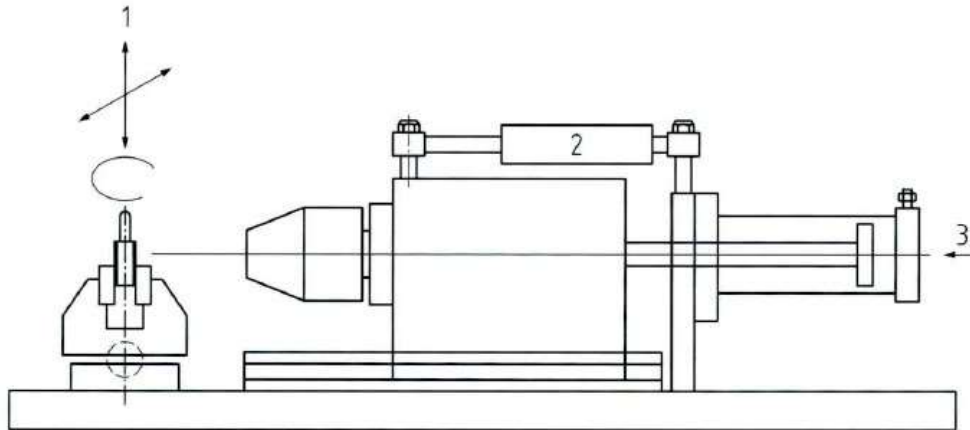

Key

- 1 Adjustable in x, y and z axis
- 2 Shock absorber
- 3 Pressure

Figure B.9: Drilling Test

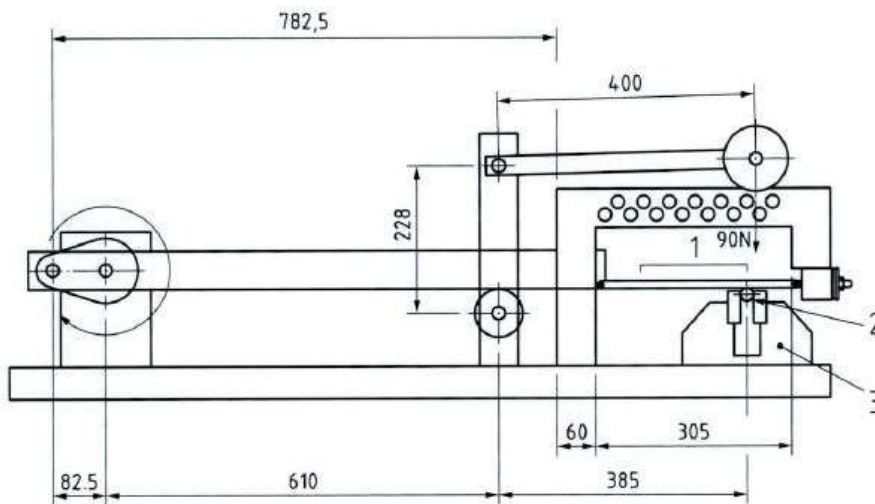

Key

- 1 165 mm stroke
- 2 Product under test
- 3 Holding fixture

Figure B.10: Sawing Test

DRAFT FOR PUBLIC COMMENTS