



Transport Canada
Safety and Security

Transports Canada
Sécurité et sûreté

Road Safety

Sécurité routière

Standards and Regulations Division

TECHNICAL STANDARDS DOCUMENT

No. 206, Revision 2

Door Locks and Door Retention Components

The text of this document is based on Federal Motor Vehicle Safety Standard No. 206, *Door Locks and Door Retention Components*, as published in the *Federal Register* on February 19, 2010 (Vol. 75, No. 33, p. 7370).

Effective Date: March 11, 2008
Mandatory Compliance Date: September 1, 2011¹

Standards Research and Development Branch
Road Safety and Motor Vehicle Regulation Directorate
TRANSPORT CANADA
Ottawa, Ontario
K1A 0N5

¹ Note: The previous mandatory compliance date was September 1, 2009.

Technical Standards Document Number 206, Revision 2

Door Locks and Door Retention Components

(Ce document est aussi disponible en français.)

Introduction

As defined by section 12 of the *Motor Vehicle Safety Act*, a Technical Standards Document (TSD) is a document that reproduces an enactment of a foreign government (e.g. a Federal Motor Vehicle Safety Standard issued by the U.S. National Highway Traffic Safety Administration). According to the Act, the *Motor Vehicle Safety Regulations* may alter or override some provisions contained in a TSD or specify additional requirements; consequently, it is advisable to read a TSD in conjunction with the Act and its counterpart Regulation. As a guide, where the corresponding Regulation contains additional requirements, footnotes indicate the amending subsection number.

TSDs are revised from time to time in order to incorporate amendments made to the reference document, at which time a Notice of Revision is published in the *Canada Gazette*, Part I. All TSDs are assigned a revision number, with “Revision 0” designating the original version.

Identification of Changes

In order to facilitate the incorporation of a TSD, certain non-technical changes may be made to the foreign enactment. These may include the deletion of words, phrases, figures, or sections that do not apply under the Act or Regulations, the conversion of imperial to metric units, the deletion of superseded dates, and minor changes of an editorial nature. Additions are underlined, and provisions that do not apply are ~~stroked through~~. Where an entire section has been deleted, it is replaced by: “[CONTENT DELETED]”. Changes are also made where there is a reporting requirement or reference in the foreign enactment that does not apply in Canada. For example, the name and address of the U.S. Department of Transportation are replaced by those of the Department of Transport.

Effective Date and Mandatory Compliance Date

The effective date of a TSD is the date of publication of its incorporating regulation or of the notice of revision in the *Canada Gazette*, and the date as of which voluntary compliance is permitted. The mandatory compliance date is the date upon which compliance with the requirements of the TSD is obligatory. If the effective date and mandatory compliance date are different, manufacturers may follow the requirements that were in force before the effective date, or those of this TSD, until the mandatory compliance date.

In the case of an initial TSD, or when a TSD is revised and incorporated by reference by an amendment to the Regulations, the mandatory compliance date is as specified in the Regulations, and it may be the same as the effective date. When a TSD is revised with no

corresponding changes to the incorporating Regulations, the mandatory compliance date is six months after the effective date.

Official Version of Technical Standards Documents

Technical Standards Documents may be consulted electronically in both HTML and Portable Document Format (PDF) on the Department of Transport's Web site at <http://www.tc.gc.ca/eng/acts-regulations/regulations-crc-c1038.htm>. The PDF version is a replica of the TSD as published by the Department and is to be used for the purposes of legal interpretation and application. The HTML version is provided for information purposes only.

(Original signed by)

Director, Standards Research and Development
for the Minister of Transport,
Infrastructure and Communities
Ottawa, Ontario

TABLE OF CONTENTS**Technical Standards Document
Number 206, Revision 2****DOOR LOCKS AND DOOR RETENTION COMPONENTS**

<i>Introduction</i> _____	<i>i</i>
<i>S1. Scope and Purpose</i> _____	<i>1</i>
<i>S2. Application</i> _____	<i>1</i>
<i>S3. Definitions</i> _____	<i>1</i>
<i>S4. Requirements</i> _____	<i>3</i>
<i>S4.1 Hinged Doors</i> _____	<i>3</i>
<i>S4.2 Sliding Side Doors</i> _____	<i>5</i>
<i>S4.3 Door Locks</i> _____	<i>6</i>
<i>S5. Test Procedures</i> _____	<i>7</i>
<i>S5.1 Hinged Doors</i> _____	<i>7</i>
<i>S5.2 Sliding Side Doors</i> _____	<i>13</i>

LIST OF FIGURES AND TABLE

Figure 1 — Evaluation of the Sliding Door Gap Separation _____	17
Figure 2 — Door Latch: Tensile Testing Fixture for Load Test 1 _____	18
Figure 3 — Door Latch: Tensile Testing Fixture for Load Test 2 _____	19
Figure 4 — Door Latch: Tensile Testing Fixture for Load Test 3 _____	20
Figure 5 — Door Latch: Static Load Test Directions _____	21
Table 1 — Acceleration Pulse Corridor _____	22
Figure 6 — Acceleration Pulse _____	22
Figure 7 — Vehicle Coordinate Reference System for Inertial Testing _____	23
Figure 8 — Hinge Static Test Fixtures _____	24
Figure 9 — Hinge Static Test Load Directions for Back Doors _____	25
Figure 10 — Sliding Side Door Full-Vehicle Test Procedure _____	26

Technical Standards Document Number 206, Revision 2

DOOR LOCKS AND DOOR RETENTION COMPONENTS

The text of this document is based on Federal Motor Vehicle Safety Standard No. 206, *Door Locks and Door Retention Components*, as published in the *Federal Register* on February 19, 2010 (Vol. 75, No. 33, p. 7370).

S1. Scope and Purpose

This Technical Standards Document (TSD) standard specifies requirements for vehicle door locks and door retention components, including latches, hinges, and other supporting means, to minimize the likelihood of occupants being ejected from a vehicle as a result of impact.

S2. Application

[CONTENT DELETED] For applicability, see Schedule III and subsections 206(1) to (3) of Schedule IV to the *Motor Vehicle Safety Regulations*.

S3. Definitions

Auxiliary door latch is a latch equipped with a fully latched position, with or without a secondary latched position, and fitted to a door or door system equipped with a primary door latch system. (*Loquet auxiliaire de porte*)

Auxiliary door latch system consists of door latches and strikers other than those associated with the primary door latch system. (*Système de fermeture auxiliaire de porte*)

* **Back door** is a door or door system on the back end of a motor vehicle through which passengers can enter or depart the vehicle or cargo can be loaded or unloaded. It does not include:

(a) A trunk lid; or

(b) A door or window composed entirely of glazing material and whose latches and/or hinge systems are attached directly to the glazing material.

(*Porte arrière*)

Body member is that portion of the hinge normally affixed to the body structure. (*Membre de carrosserie*)

* Please see subsection 2(1) of the *Motor Vehicle Safety Regulations* for the applicable definition.

Door closure warning system is a system that will activate a visual signal when a door latch system is not in its fully latched position and the vehicle ignition is activated. (*Système d'avertissement de fermeture de porte*)

Door hinge system is one or more hinges used to support a door. (*Système de charnières de porte*)

Door latch system consists of latches and strikers installed on a door system. (*Système de fermeture de porte*)

Door member is that portion of the hinge normally affixed to the door structure and constituting the swinging member. (*Membre de porte*)

Door system is the door, latch, striker, hinges, sliding track combinations, and other door retention components on a door and its surrounding door frame. The door system of a double door includes both doors. (*Système de porte*)

Double door is a system of two doors where the front door or wing door opens first and connects to the rear door or bolted door, which opens second. (*Porte double*)

Folding door is a movable barrier which ~~will~~ closes off an entranceway to a bus, multipurpose passenger vehicle, or truck, consisting of two or more hinged panels that swing, slide, or rotate, and which does not have a striker and latch assembly. (*Porte pliante*)

Fork-bolt is the part of the latch that engages and retains the striker when in a latched position. (*Fourchette de loquet*)

Fork-bolt opening direction is the direction opposite to that in which the striker enters the latch to engage the fork-bolt. (*Direction d'ouverture de la fourchette de loquet*)

Fully latched position is the coupling condition of the latch that retains the door in a completely closed position. (*Position de fermeture complète*)

Hinge is a device system used to position the door relative to the body structure and control the path of the door swing for passenger ingress and egress. (*Charnière*)

Hinge pin is that portion of the hinge normally interconnecting the body and door members and establishing the swing axis. (*Pivot de charnière*)

Latch is a device employed to maintain the door in a closed position relative to the vehicle body with provisions for deliberate release (or operation). (*Loquet*)

Primary door latch is a latch equipped with both a fully latched position and a secondary latched position and that is designated as a “primary door latch” by the manufacturer. (*Loquet primaire de porte*)

Primary door latch system consists of a primary door latch(s) and a striker(s). (*Système de fermeture primaire de porte*)

Secondary latched position refers to the coupling condition of the latch that retains the door in a partially closed position. (*Position de fermeture intermédiaire*)

Side front door is a door that, in a side view, has 50 percent or more of its opening area forward of the rearmost point on the driver's seat back, when the seat back is adjusted to its most vertical and rearward position. (*Porte latérale avant*)

Side rear door is a door that, in a side view, has 50 percent or more of its opening area to the rear of the rearmost point on the driver's seat back, when the driver's seat is adjusted to its most vertical and rearward position. (*Porte latérale arrière*)

Striker is a device with which the latch engages to maintain the door in the fully latched or secondary latched position. (*Gâche*)

Trunk lid means a movable body panel that provides access from outside the vehicle to a space that is wholly partitioned from the occupant compartment by a permanently attached partition or a fixed or fold-down seat back. (*Couvercle de coffre*)

S4. Requirements

The requirements apply to all side and back doors, that lead directly into a compartment that contains one or more seating accommodations and the associated door components, except for those on folding doors, roll-up doors, detachable doors, bus doors used only for emergency egress purposes and labeled accordingly and on bus doors to accommodate a permanently attached wheelchair lift system that when the device is in the retracted position, the lift platform retracts to a vertical orientation parallel to and in close proximity with the interior surface of the lift door and in that position, the platform completely covers the doorway opening, has fixed attachments to the vehicle and provides a barricade to the doorway. The bus wheelchair lift door must be linked to an alarm system consisting of either a flashing visible signal located in the driver's compartment or an alarm audible to the driver that is activated when the door is not fully closed and the vehicle ignition is activated.

S4.1 Hinged Doors

S4.1.1 Primary and Auxiliary Door Latch Systems. Each hinged door system shall be equipped with at least one primary door latch system. By the time a vehicle is certified, a manufacturer shall designate the door latch system(s) that is the "primary door latch system(s)." Upon certification, a manufacturer may not thereafter alter the designation of a primary door latch system. Each manufacturer shall, upon request from Transport Canada ~~the National Highway Traffic Safety Administration~~, provide information regarding such designation.

S4.1.1.1 Load Test One

- (a) Each primary door latch system and auxiliary door latch system, when in the fully latched position, shall not separate when a load of 11 000 N is applied in the direction perpendicular to the face of the latch such that the latch and the striker anchorage are not compressed against each other, when tested in accordance with S5.1.1.1.

- (b) When in the secondary latched position, the primary door latch system shall not separate when a load of 4 500 N is applied in the same direction specified in paragraph (a) of this section, when tested in accordance with S5.1.1.1.

S4.1.1.2 Load Test Two

- (a) Each primary door latch system and auxiliary door latch system, when in the fully latched position, shall not separate when a load of 9 000 N is applied in the fork-bolt opening direction and parallel to the face of the latch, when tested in accordance with S5.1.1.2.
- (b) When in the secondary latched position, the primary door latch system shall not separate when a load of 4 500 N is applied in the same direction specified in paragraph (a) of this section, when tested in accordance with S5.1.1.2.

S4.1.1.3 Load Test Three. (Applicable only to back doors that open in a vertical direction.) Each primary door latch system on back doors, when in the fully latched position, shall not separate when a load of 9 000 N is applied in a direction orthogonal to the directions specified in S4.1.1.1 and S4.1.1.2, when tested in accordance with S5.1.1.3.

S4.1.1.4 Inertial Load. Each primary door latch system and auxiliary door latch system shall meet either the dynamic requirements specified in paragraphs (a) and (b) of S4.1.1.4 or the calculation of inertial load resistance specified in paragraph (c) of S4.1.1.4.

- (a) Each primary door latch and auxiliary door latch on each hinged door shall not disengage from the fully latched position when an inertial load is applied to the door latch system, including the latch and its activation device, in the directions parallel to the vehicle's longitudinal and transverse axes with the locking device disengaged, when tested as specified in S5.1.1.4(b).
- (b) Each primary door latch and auxiliary door latch on each hinged back door shall also not disengage from the fully latched position when an inertial load is applied to the door latch system, including the latch and its activation device, in the direction parallel to the vehicle's vertical axis with the locking device disengaged, when tested as specified in S5.1.1.4(b).
- (c) Each component or subassembly is calculated for its minimum inertial load resistance in a particular direction. The combined resistance to the unlatching operation must assure that the door latch system, when properly assembled in the vehicle door, will remain latched when subjected to an inertial load of 30 g in the vehicle directions specified in paragraph (a) of this section or paragraph (b) of this section, as applicable, when calculated in accordance with S5.1.1.4(a).

S4.1.2 Door Hinges

S4.1.2.1 When tested in accordance with S5.1.2, each door hinge system shall:

- (a) Support the door,
- (b) Not separate when a longitudinal load of 11 000 N is applied,
- (c) Not separate when a transverse load of 9 000 N is applied, and

- (d) For back doors,
- (1) Not separate when a load of 11 000 N is applied perpendicular to the hinge face plate (longitudinal load test) such that the hinge plates are not compressed against each other (Load Test One).
 - (2) Not separate when a load of 9 000 N is applied perpendicular to the axis of the hinge pin and parallel to the hinge face plate (transverse load test) such that the hinge plates are not compressed against each other (Load Test Two).
 - (3) Not separate when a load of 9 000 N is applied in the direction of the axis of the hinge pin (Load Test Three—only for back doors that open in a vertical direction).

S4.1.2.2 If a single hinge within the hinge system is tested instead of the entire hinge system, the hinge must bear a load proportional to the total number of hinges in the hinge system. (For example, an individual hinge in a two-hinge system must be capable of withstanding 50% of the load requirements of the total system.)

S4.1.2.3 On side doors with rear mounted hinges that can be operated independently of other doors,

- (a) The interior door handle shall be inoperative when the speed of the vehicle is greater than or equal to 4 km/h, and
- (b) A door closure warning system shall be provided for those doors. The door closure warning system shall be located where it can be clearly seen by the driver.

S4.2 Sliding Side Doors

S4.2.1 Latch System. Each sliding door system shall be equipped with either:

- (a) At least one primary door latch system, or
- (b) A door latch system with a fully latched position and a door closure warning system. The door closure warning system shall be located where it can be clearly seen by the driver.

Note: By the time a vehicle is certified, a manufacturer shall designate the door latch system(s) that is the “primary door latch system(s).” Upon certification, a manufacturer may not thereafter alter the designation of a primary door latch. Each manufacturer shall, upon request from Transport Canada the National Highway Traffic Safety Administration, provide information regarding such designation.

S4.2.1.1 Load Test One

- (a) At least one door latch system, when in the fully latched position, shall not separate when a load of 11 000 N is applied in the direction perpendicular to the face of the latch such that the latch and the striker anchorage are not compressed against each other, when tested in accordance with S5.2.1.1.
- (b) In the case of a primary door latch system, when in the secondary latched position, the door latch system shall not separate when a load of 4 500 N is applied in the same

direction specified in paragraph (a) of this section, when tested in accordance with S5.2.1.1.

S4.2.1.2 Load Test Two

- (a) At least one door latch system, when in the fully latched position, shall not separate when a load of 9 000 N is applied in the fork-bolt opening direction and parallel to the face of the latch, when tested in accordance with S5.2.1.2.
- (b) In the case of a primary door latch system, when in the secondary latched position, the door latch system shall not separate when a load of 4 500 N is applied in the same direction specified in paragraph (a) of this section, when tested in accordance with S5.2.1.2.

S4.2.1.3 Inertial Load. Each door latch system certified as meeting the requirements of S4.2.1.1 and S4.2.1.2 shall meet either the dynamic requirements specified in paragraph (a) of this section or the calculation of inertial load resistance specified in paragraph (b) of this section.

- (a) The door latch system shall not disengage from the fully latched position when an inertial load is applied to the door latch system, including the latch and its activation mechanism, in the directions parallel to the vehicle's longitudinal and transverse axes with the locking mechanism disengaged, and when tested in accordance with S5.1.1.4(b).
- (b) The minimum inertial load resistance can be calculated for each component or subassembly. Their combined resistance to the unlatching operation must assure that the door latch system, when properly assembled in the vehicle door, will remain latched when subjected to an inertial load of 30 g in the vehicle directions specified in paragraph (a) of this section, when calculated in accordance with S5.1.1.4(a).

S4.2.2 Door System

S4.2.2.1 The track-and-slide combination or other supporting means for each sliding door, while in the closed, fully latched position, shall not separate from the door frame when a total force of 18 000 N along the vehicle's transverse axis is applied to the door, as specified in S5.2.2.

S4.2.2.2 When a sliding door system is tested in accordance with S5.2.2, the following conditions shall not occur:

- (a) A separation which permits a sphere with a diameter of 100 mm to pass unobstructed between the exterior of the vehicle to the interior of the vehicle, while the required force is maintained as shown in Figure 1.
- (b) Either force application device reaches a total displacement of 300 mm.

S4.3 Door Locks

Each door shall be equipped with at least one locking device which, when engaged, shall prevent operation of the exterior door handle or other exterior latch release control and which

has an operating means and a lock release/engagement device located within the interior of the vehicle.

S4.3.1 Rear Side Doors

Each rear side door shall be equipped with at least one locking device which has a lock release/engagement mechanism located within the interior of the vehicle and which is readily accessible to the driver of the vehicle or an occupant seated adjacent to the door, and which, when engaged, prevents operation of the interior door handle or other interior latch release control and requires separate actions to unlock the door and operate the interior door handle or other interior latch release control.

S4.3.2 Back Doors

Each back door equipped with an interior door handle or other interior latch release control shall be equipped with at least one locking device that meets the requirements of S4.3.1.

S5. Test Procedures

S5.1 Hinged Doors

S5.1.1 Primary and Auxiliary Door Latches

S5.1.1.1 Load Test One Force Application. The test procedures for S4.1.1.1 and S4.2.1.1 are as follows:

(a) *Fully Latched Position*

- (1) Attach the test fixture shown in Figure 2 to the mounting provisions of the latch and striker. Align the direction of engagement parallel to the linkage of the fixture. Mount the fixture with the latch and striker in the fully latched position in the test machine so as to apply a load perpendicular to the face of the latch.
- (2) Locate weights so as to apply a 900-N load tending to separate the latch and striker in the direction of the latch opening.
- (3) Apply the test load, in the direction specified in S4.1.1.1 and Figure 5, at a rate not to exceed 5 mm/min until the required load has been achieved. Record the maximum load achieved.

(b) *Secondary Latched Position*

- (1) Attach the test fixture shown in Figure 2 to the mounting provisions of the latch and striker. Align the direction of engagement parallel to the linkage of the fixture. Mount the fixture with latch and striker in the secondary latched position in the test machine so as to apply a load perpendicular to the face of the latch.
- (2) Locate weights so as to apply a 900-N load tending to separate the latch and striker in the direction of the latch opening.
- (3) Apply the test load, in the direction specified in S4.1.1.1 and Figure 5, at a rate not to exceed 5 mm/min until the required load has been achieved. Record maximum load achieved.

- (4) The test plate to which the door latch is mounted will have a striker cut-out configuration similar to the environment in which the door latch will be mounted on normal vehicle doors.

S5.1.1.2 Load Test Two Force Application. The test procedures for S4.1.1.2 and S4.2.1.2 are as follows:

(a) *Fully Latched Position*

- (1) ~~Attach~~ Adapt the test fixture shown in Figure 3 to the mounting provisions of the latch and striker. Mount the fixture with latch and striker in the fully latched position in the test machine so as to apply a load in the direction of latch opening.
- (2) Apply the test load, in the direction specified in S4.1.1.2 and Figure 5, at a rate not to exceed 5 mm/min until the required load has been achieved. Record the maximum load achieved.

(b) *Secondary Latched Position*

- (1) ~~Attach~~ Adapt the test fixture shown in Figure 3 to the mounting provisions of the latch and striker. Mount the fixture with latch and striker in the secondary latched position in the test machine so as to apply a load in the direction of latch opening.
- (2) Apply the test load, in the direction specified in S4.1.1.2 and Figure 5, at a rate not to exceed 5 mm/min until the required load has been achieved. Record the maximum load achieved.

S5.1.1.3 Load Test Three Force Application. The test procedures for S4.1.1.3 are as follows:

- (a) ~~Attach~~ Adapt the test fixture shown in Figure 4 to the mounting provisions of the latch and striker. Mount the fixture with latch and striker in the fully latched position in the test machine so as to apply a load in the direction specified in S4.1.1.3 and Figure 5.
- (b) Apply the test load, in the direction specified in S4.1.1.3 and Figure 5, at a rate not to exceed 5 mm/min until the required load has been achieved. Record the maximum load required.

S5.1.1.4 Inertial Force Application. The test procedures for S4.1.1.4 and S4.2.1.3 are as follows:

- (a) *Calculation.* The calculation is performed in accordance with paragraph 6 of Society of Automotive Engineers Recommended Practice J839, *Passenger Car Side Door Latch Systems*, June 1991.

- (b) *Dynamic Test.* The dynamic inertial force application is tested according to the setup specified in paragraph (1) or (2) of this section.

(1) Test Setup and Directions for Full Vehicle Test

(i) *Test Setup*

- (A) Rigidly secure the full vehicle to an acceleration device that, when accelerated together, will assure that all points on the crash pulse curve are within the corridor defined in Table 1 and Figure 6.
- (B) Install the equipment used to record door opening (doors may be tethered to avoid damaging the recording equipment).
- (C) Close the door(s) to be tested and ensure that the door latch(es) is in the fully-latched position, that the door(s) is unlocked, and that all windows, if provided, on the door(s) are closed.

(ii) *Test Directions* (See Figure 7)

- (A) Longitudinal Setup 1. Orient the vehicle so that its longitudinal axis is aligned with the axis of the acceleration device, simulating a frontal impact.
- (B) Longitudinal Setup 2. Orient the vehicle so that its longitudinal axis is aligned with the axis of the acceleration device, simulating a rear impact.
- (C) Transverse Setup 1. Orient the vehicle so that its transverse axis is aligned with the axis of the acceleration device, simulating a driver-side impact.
- (D) Transverse Setup 2. (Only for vehicles having different door arrangements on each side.) Orient the vehicle so that its transverse axis is aligned with the axis of the acceleration device, simulating a side impact in the direction opposite to that described in (b)(1)(ii)(C) of this paragraph.

(2) Test Setup and Directions for Door Test

(i) *Test Setup*

- (A) Mount the door assemblies, consisting of at least the door latch(es), exterior door handle(s) with mechanical latch operation, interior door opening lever(s), and locking device(s), either separately or combined, to a test fixture. Each door and striker is mounted to the test fixture to correspond to its orientation on the vehicle and to the directions specified in (b)(1)(ii) of this paragraph.
- (B) Mount the test fixture to the acceleration device and install the equipment used to record door opening.

- (C) Ensure that the door latch is in the fully-latched position, that the door is unlocked (doors may be tethered to avoid damaging the recording equipment), and that any windows, if provided, are closed.
- (ii) *Test Directions* (See Figure 7)
 - (A) Longitudinal Setup 1. Orient the door subsystem(s) on the acceleration device in the direction of a frontal impact.
 - (B) Longitudinal Setup 2. Orient the door subsystem(s) on the acceleration device in the direction of a rear impact.
 - (C) Transverse Setup 1. Orient the door subsystem(s) on the acceleration device in the direction of a driver-side impact.
 - (D) Transverse Setup 2. Orient the door subsystem(s) on the acceleration device in the direction opposite to that described in (b)(2)(ii)(C) of this paragraph.
 - (E) Vertical Setup 1 (applicable only to back doors that open in a vertical direction). Orient the door subsystem(s) on the acceleration device so that its vertical axis (when mounted in the vehicle) is aligned with the axis of the acceleration device, simulating a rollover impact where the force is applied in the direction from the top to the bottom of the door (when mounted in a vehicle).
 - (F) Vertical Setup 2 (applicable only to back doors that open in a vertical direction). Orient the door subsystem(s) on the acceleration device so that its vertical axis (when mounted in the vehicle) is aligned with the axis of the acceleration device, simulating a rollover impact where the force is applied in the direction opposite to that described in (b)(2)(ii)(E) of this paragraph.

(3) Test Operation

- (i) The acceleration device platform shall be instrumented with an accelerometer and data processing system that conforms to the requirements specified in Society of Automotive Engineers (SAE) Recommended Practice J211, December 2003, *Instrumentation for Impact Test—Part 1—Electronic Instrumentation*, Channel Class 60. The accelerometer sensitive axis is parallel to the direction of test platform travel.
- (ii) Maintaining a minimum acceleration level of 30 g for a period of at least 30 ms, while keeping the recorded acceleration within the pulse corridor defined in Table 1 and Figure 6, accelerate the acceleration device in the following directions:
 - (A) For Full Vehicle Tests, in the directions specified in S5.1.1.4(b)(1)(ii)(A) through S5.1.1.4(b)(1)(ii)(D).
 - (B) For Door Tests, in the directions specified in S5.1.1.4(b)(2)(ii)(A) through S5.1.1.4(b)(2)(ii)(F).

- (iii) Check the recording device for door opening and/or closure during the test.
- (iv) If, at any point in time, the pulse exceeds 36 g and the test specifications are met, the test shall be considered valid.

S5.1.2 Door Hinges. The test procedures for S4.1.2 are as follows:

S5.1.2.1 Multiple Hinge Evaluation

S5.1.2.1.1 Longitudinal Load Test

- (a) Attach the test fixture illustrated in Figure 8 to the mounting provisions of the hinge system. Hinge attitude is configured to simulate vehicle position (door fully closed) relative to the hinge centreline. For test purposes, the distance between the extreme end of one hinge in the system to the extreme end of another hinge in the system is to be set at $406 \text{ mm} \pm 4 \text{ mm}$. The load is to be applied equidistant between the linear centre of the engaged portions of the hinge pins and through the centreline of the hinge pin in the longitudinal vehicle direction (see Figure 8).
- (b) Apply the test load at a rate not to exceed 5 mm/min until the required load has been achieved. Record the maximum load achieved.

S5.1.2.1.2 Transverse Load Test

- (a) Attach the test fixture shown in Figure 8 to the mounting provisions of the hinge system. Hinge attitude is configured to simulate vehicle position (door fully closed) relative to the hinge centreline. For test purposes, the distance between the extreme end of one hinge in the system to the extreme opposite end of another hinge in the system is to be set at $406 \text{ mm} \pm 4 \text{ mm}$. The load is to be applied equidistant between the linear centre of the engaged portions of the hinge pins and through the centreline of the hinge pin in the transverse vehicle direction (see Figure 8).
- (b) Apply the test load at a rate not to exceed 5 mm/min until the required load has been achieved. Record the maximum load achieved.

S5.1.2.2 Back Door Hinge Load Test

(a) Load Test One

- (1) Attach the test fixture illustrated in Figure 8 to the mounting provisions of the hinge system. Hinge attitude is configured to simulate vehicle position (door fully closed) relative to the hinge centreline. For test purposes, the distance between the extreme end of one hinge ~~system~~ in the system to the extreme opposite end of another hinge in the system is to be set at $406 \text{ mm} \pm 4 \text{ mm}$. The load is to be applied equidistant between the linear centre of the engaged portions of the hinge pins and through the centreline of the hinge pin, and as specified in S4.1.2.1(d)(1) (see Figure 9).
- (2) Apply the test load at a rate not to exceed 5 mm/min until the required load has been achieved. Failure consists of a separation of either hinge. Record the maximum load achieved.

(b) *Load Test Two*

- (1) Attach the test fixture illustrated in Figure 8 to the mounting provisions of the hinge system. Hinge attitude is configured to simulate vehicle position (door fully closed) relative to the hinge centreline. For test purposes, the distance between the extreme end of one hinge system in the system to the extreme opposite end of another hinge in the system is to be set at $406 \text{ mm} \pm 4 \text{ mm}$. The load is to be applied equidistant between the linear centre of the engaged portions of the hinge pins and through the centreline of the hinge pin, and as specified in S4.1.2.1(d)(2) (see Figure 9).
- (2) Apply the test load at a rate not to exceed 5 mm/min until the required load has been achieved. Failure consists of a separation of either hinge. Record the maximum load achieved.

(c) *Load Test Three*

- (1) Attach the test fixture illustrated in Figure 8 to the mounting provisions of the hinge system. Hinge attitude is configured to simulate vehicle position (door fully closed) relative to the hinge centreline. For test purposes, the distance between the extreme end of one hinge system in the system to the extreme opposite end of another hinge in the system is to be set at $406 \text{ mm} \pm 4 \text{ mm}$. The load is to be applied through the centreline of the hinge pin, and as specified in S4.1.2.1(d)(3) (see Figure 9).
- (2) Apply the test load at a rate not to exceed 5 mm/min until the required load has been achieved. Failure consists of a separation of either hinge. Record the maximum load achieved.

S5.1.2.3 Single Hinge Evaluation. Individual hinges of a hinge system are tested in accordance with the procedures below:

- (a) *Longitudinal Load.* Attach the test fixture illustrated in Figure 8 to the mounting provisions of the hinge. Hinge attitude is configured to simulate the vehicle position (door fully closed) relative to the hinge centreline. For test purposes, the load is to be applied equidistant between the linear centre of the engaged portions of the hinge pin and through the centreline of the hinge pin in the longitudinal vehicle direction. Apply the test load at a rate not to exceed 5 mm/min until the required load has been achieved. Failure consists of a separation of the either hinge. Record the maximum load achieved.
- (b) *Transverse Load.* Attach the test fixture illustrated in Figure 8 to the mounting provisions of the hinge. Hinge attitude is configured to simulate the vehicle position (door fully closed) relative to the hinge centreline. For test purposes, the load is to be applied equidistant between the linear centre of the engaged portions of the hinge pin and through the centreline of the hinge pin in the transverse vehicle direction. Apply the test load at a rate not to exceed 5 mm/min until the required load has been achieved. Failure consists of a separation of the either hinge. Record the maximum load achieved.

(c) *Back Door Hinge Load Tests*

- (1) **Load Test One.** Attach the test fixture illustrated in Figure 8 to the mounting provisions of the hinge. Hinge attitude is configured to simulate the vehicle position (door fully closed) relative to the hinge centreline. For test purposes, the load is to be applied equidistant between the linear centre of the engaged portions of the hinge pin and through the centreline of the hinge pin, and as specified in S4.1.2.1(d)(1) (see Figure 9). Apply the test load at a rate not to exceed 5 mm/min until the required load has been achieved. Failure consists of a separation of the either hinge. Record the maximum load achieved.
- (2) **Load Test Two.** Attach the test fixture illustrated in Figure 8 to the mounting provisions of the hinge. Hinge attitude is configured to simulate the vehicle position (door fully closed) relative to the hinge centreline. For test purposes, the load is to be applied equidistant between the linear centre of the engaged portions of the hinge pin and through the centreline of the hinge pin, and as specified in S4.1.2.1(d)(2) (see Figure 9). Apply the test load at a rate not to exceed 5 mm/min until the required load has been achieved. Failure consists of a separation of the either hinge. Record the maximum load achieved.
- (3) **Load Test Three.** Attach the test fixture illustrated in Figure 8 to the mounting provisions of the hinge. Hinge attitude is configured to simulate the vehicle position (door fully closed) relative to the hinge centreline. For test purposes, the load is to be applied through the centreline of the hinge pin, and as specified in S4.1.2.1(d)(3) (see Figure 9). Apply the test load at a rate not to exceed 5 mm/min until the required load has been achieved. Failure consists of a separation of the either hinge.

S5.1.2.4 For piano-type hinges, the hinge spacing requirements are not applicable and arrangement of the test fixture is altered so that the test forces are applied to the complete hinge.

S5.2 Sliding Side Doors

S5.2.1 Door Latches

S5.2.1.1 Load Test One Force Application. Compliance with the requirements of S4.2.1.1 is tested in accordance with the procedures specified in S5.1.1.1.

S5.2.1.2 Load Test Two Force Application. Compliance with the requirements of S4.2.1.2 is tested in accordance with the procedures specified in S5.1.1.2.

S5.2.1.3 [Reserved]

S5.2.1.4 [Reserved]

S5.2.2 Door System. The test procedures for S4.2.2 are as follows:

S5.2.2.1 Tests are conducted using a full vehicle with the sliding door and its retention components.

S5.2.2.2 The test is conducted using two force application devices capable of applying the outward transverse forces specified in S5.2.2.4. The test setup is shown in Figure 10. The force application system shall include the following:

- (a) Two force application plates.
- (b) Two force application devices capable of applying the outward transverse load requirements for a minimum displacement of 300 mm.
- (c) Two load cells of sufficient capacity to measure the applied loads specified in S5.2.2.4.
- (d) Two linear displacement measurement devices required for measuring force application device displacement during the test.
- (e) Equipment to measure for a 100-mm separation, as specified in S4.2.2.2(a), while respecting all relevant safety and health requirements.

S5.2.2.3 Test Setup

- (a) Remove all interior trim and decorative components from the sliding door assembly.
- (b) Remove seats and any interior components that may interfere with the mounting and operation of the test equipment and remove all pillar trim and any non-structural components that overlap the door and cause improper placement of the force application plates.
- (c) Each force application device and associated support structure is rigidly fixed on a horizontal surface on the vehicle floor while applying the loads.
- (d) Determine the forward and aft edges of the sliding door, or its adjoining vehicle structure, that contains a latch/striker.
- (e) Close the sliding door, ensuring that all door retention components are fully engaged.
- (f) For any tested door edge that contains one latch/striker, the following setup procedures are used:
 - (1) (i) The force application plate is 150 mm in length, 50 mm in width, and at least 15 mm in thickness. The plate edges are rounded to a radius of 6 mm \pm 1 mm.
 - (ii) The plates are fixed perpendicular to the force application devices and move in the transverse direction. For alignment purposes, each plate is attached to the application device in a manner that allows for rotation about the vehicle's y-axis. In this manner, the face of each plate remains parallel to the vertical plane which passes through the vehicle's longitudinal centerline.
- (2) Place the force application device and force application plate against the door so that the applied force is perpendicular to the vertical longitudinal plane that passes through the vehicle's longitudinal centreline and vertically centred on the door-mounted portion of the latch/striker.

- (3) The force application plate is positioned such that the long edge of the plate is as close to the interior edge of the door as possible, but not such that the forward edge of forward plate and the rear edge of the rear plate are more than 12.5 mm from the respective interior edges.
- (g) For any tested door edge that contains more than one latch/striker, the following setup procedures are used:
- (1) (i) The force application plate is 300 mm in length, 50 mm in width, and at least 15 mm in thickness. The plate edges are rounded to a radius of 6 mm \pm 1 mm.
 - (ii) The plates are fixed perpendicular to the force application devices and move in the transverse direction. For alignment purposes, each plate is attached to the application device in a manner that allows for rotation about the vehicle's y-axis. In this manner, the face of each plate remains parallel to the vertical plane, which passes through the vehicle's longitudinal centerline.
- (2) Place the force application device and force application plate against the door so that the applied force is perpendicular to the vertical longitudinal plane that passes through the vehicle's longitudinal centreline and vertically centred on a point midway between the outermost edges of the latch/striker assemblies.
- (3) The force application plate is positioned such that the long edge of the plate is as close to the interior edge of the door as possible, but not such that the forward edge of forward plate and the rear edge of the rear plate are more than 12.5 mm from the respective interior edges.
- (h) For any tested door edge that does not contain at least one latch/striker, the following setup procedures are used:
- (1) (i) The force application plate is 300 mm in length, 50 mm in width, and at least 15 mm in thickness. The plate edges are rounded to a radius of 6 mm \pm 1 mm.
 - (ii) The plates are fixed perpendicular to the force application devices and move in the transverse direction. For alignment purposes, each plate is attached to the application device in a manner that allows for rotation about the vehicle's y-axis. In this manner, the face of each plate remains parallel to the vertical plane, which passes through the vehicle's longitudinal centerline.
- (2) Place the force application device and force application plate against the door so that the applied force is perpendicular to the vertical longitudinal plane that passes through the vehicle's longitudinal centreline and vertically centred on a point midway along the length of the door edge, ensuring that the loading device avoids contact with the window glazing.
- (3) The force application plate is positioned such that the long edge of the plate is as close to the interior edge of the door as possible, but not such that the forward edge of forward plate and the rear edge of the rear plate are more than 12.5 mm from the respective interior edges.

- (i) The door is unlocked. No extra fixtures or components may be welded or affixed to the sliding door or any of its components.
- (j) Place the load application structure so that the force application plates are in contact with the interior of the sliding door.
- (k) Apply a preload of 500 N to each actuator and “zero” the displacement measuring device.

S5.2.2.4 Test Procedure

- (a) Increase the force on each force application device as linearly as practicable until a force of 9,000 N is achieved on each force application device in not less than 90 seconds and not more than 120 seconds, or until either force application device reaches a total displacement of 300 mm.
- (b) If one of the force application devices reaches the target force of 9 000 N prior to the other, maintain the 9 000-N force with that force application device until the second force application device reaches the 9 000-N force.
- (c) Once both force application devices have achieved 9 000 N each, hold the resulting load.
- (d) Maintain each force application device load as specified in paragraph (c) and within 30 seconds measure the separation between the exterior edge of the door frame and the interior of the door along the perimeter of the door.

S5.3 [Reserved]

Top View — Pre-Test

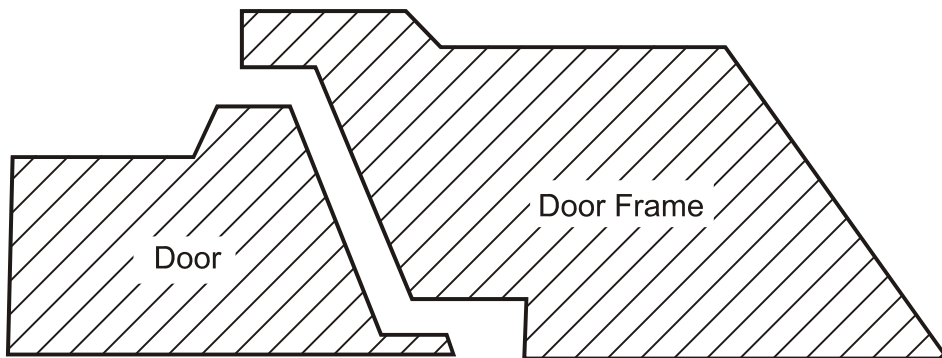

Exterior of vehicle

Top View — During Force Application

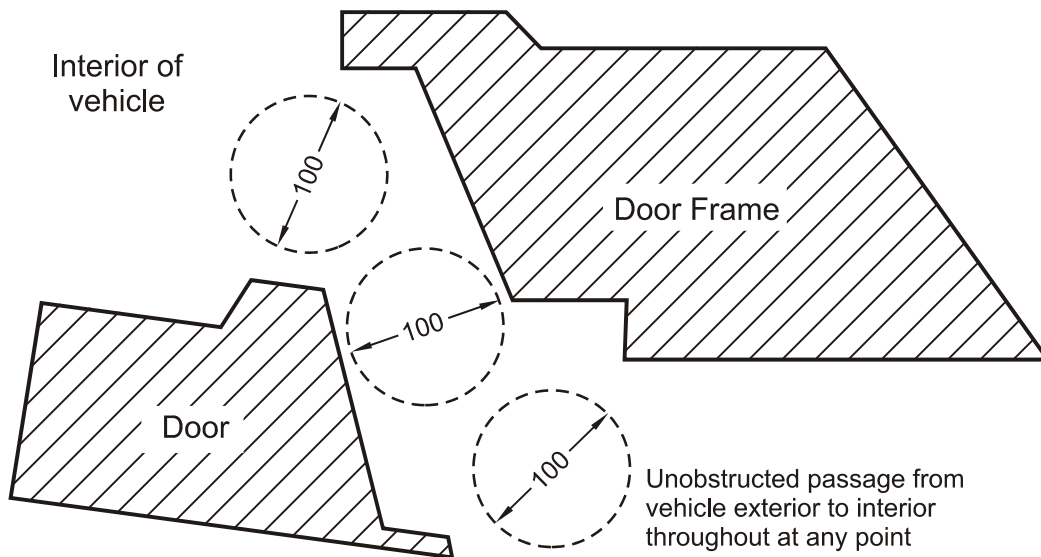

- Notes:
1. Dimensions in mm
 2. Not to scale

Figure 1 — Evaluation of the Sliding Door Gap Separation

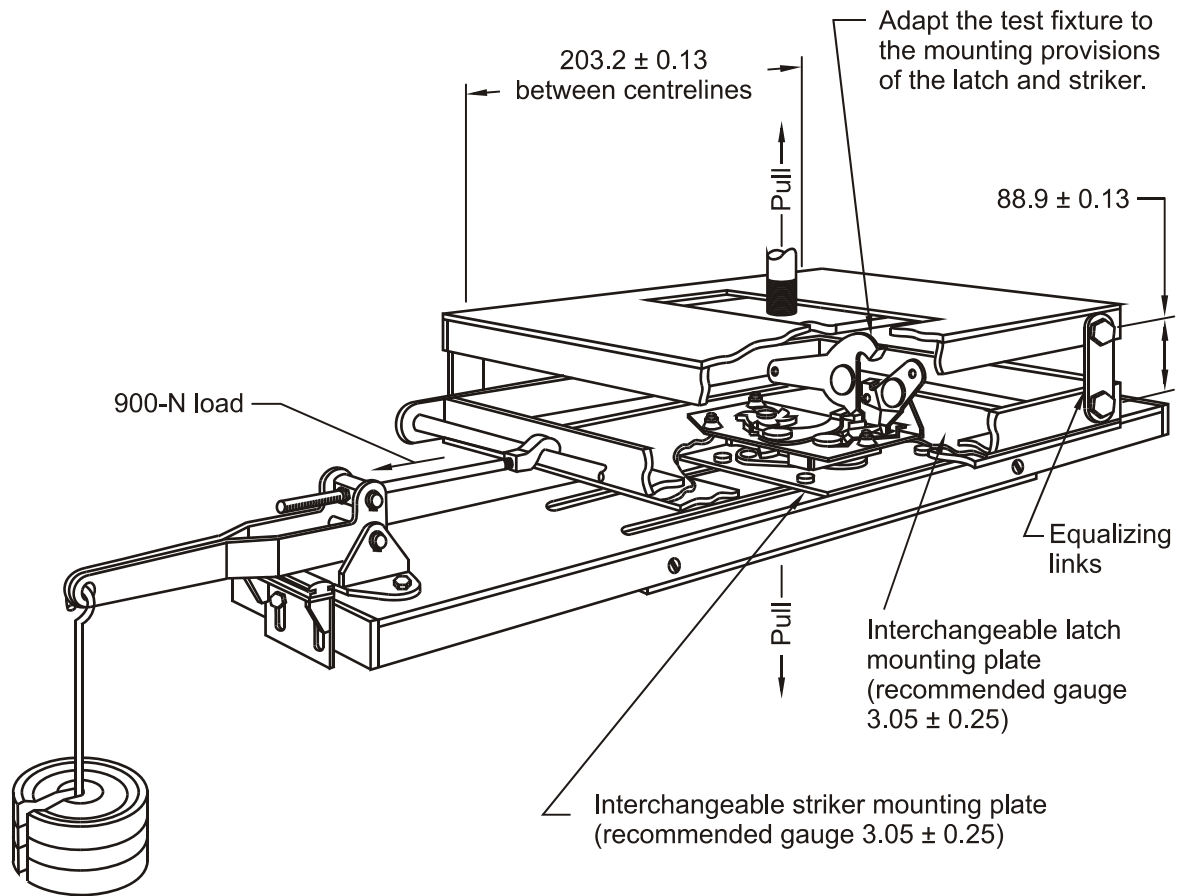

Notes:

1. Dimensions in mm
2. Not to scale

Figure 2 — Door Latch: Tensile Testing Fixture for Load Test 1

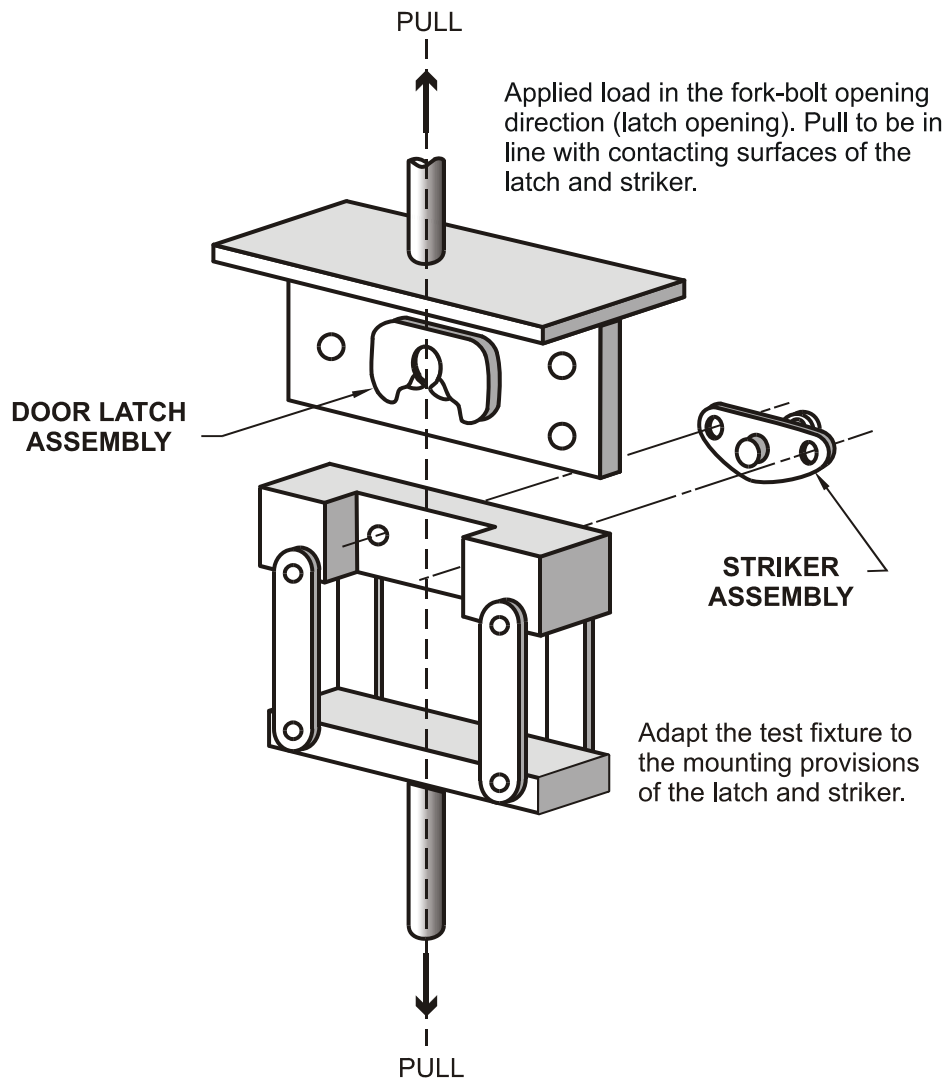

Figure 3 — Door Latch: Tensile Testing Fixture for Load Test 2

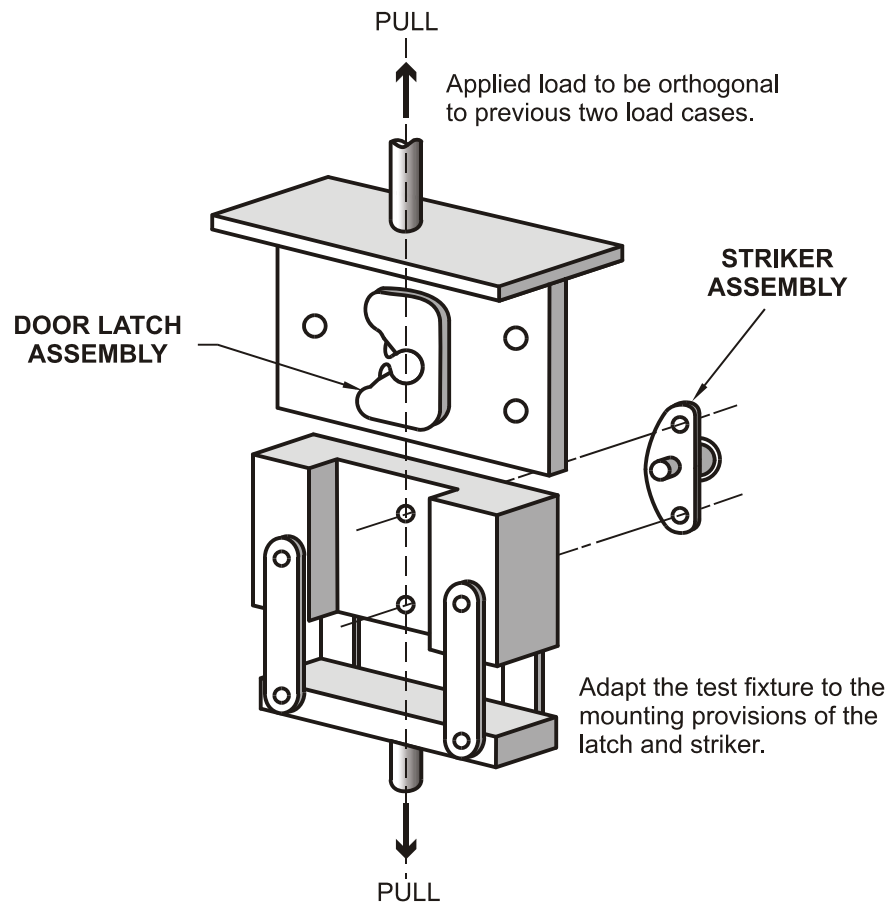

Figure 4 — Door Latch: Tensile Testing Fixture for Load Test 3 (Back Doors Only)

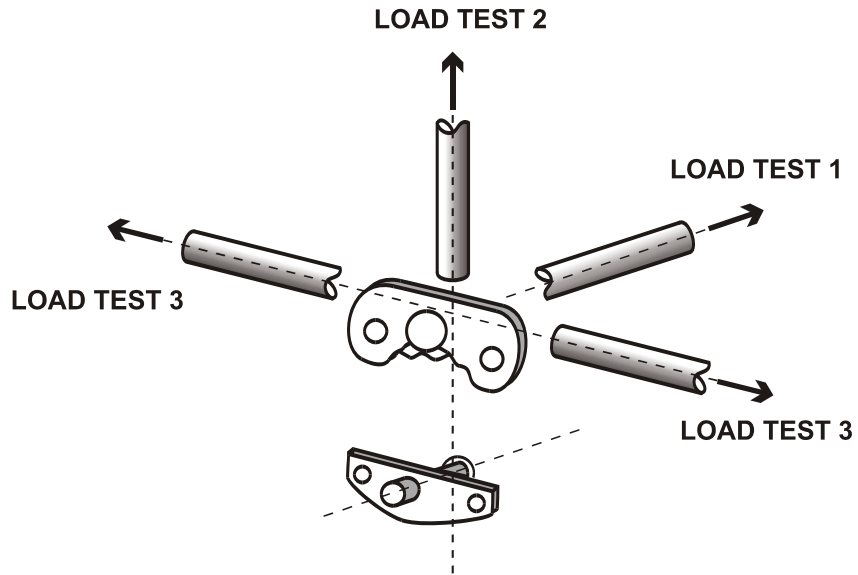

Figure 5 — Door Latch: Static Load Test Directions

Table 1 — Acceleration Pulse Corridor

Upper Bound			Lower Bound		
Point	Time (ms)	Acceleration (g)	Point	Time (ms)	Acceleration (g)
A	0	6	E	5	0
B	20	36	F	25	30
C	60	36	G	55	30
D	100	0	H	70	0

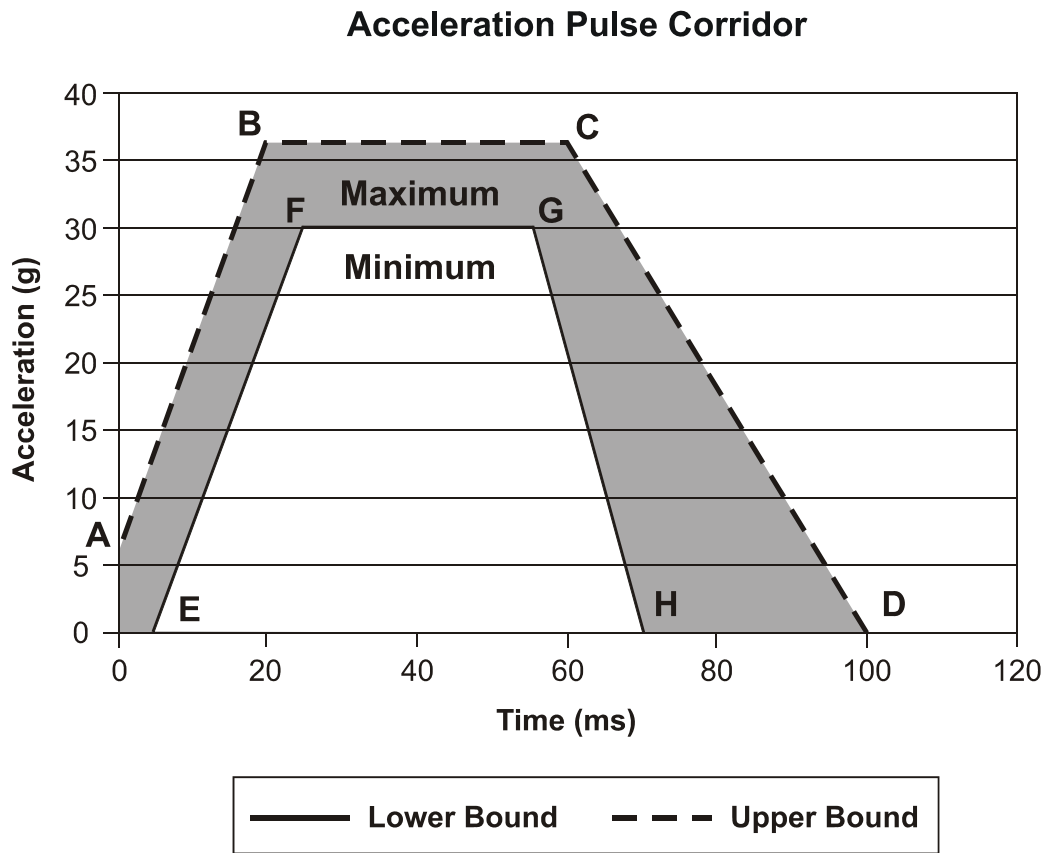
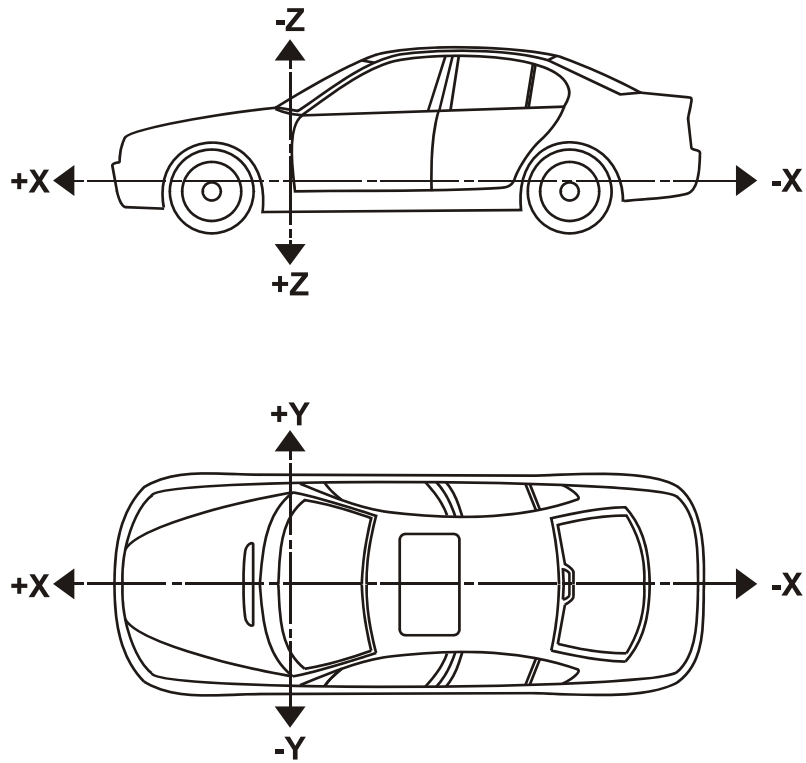
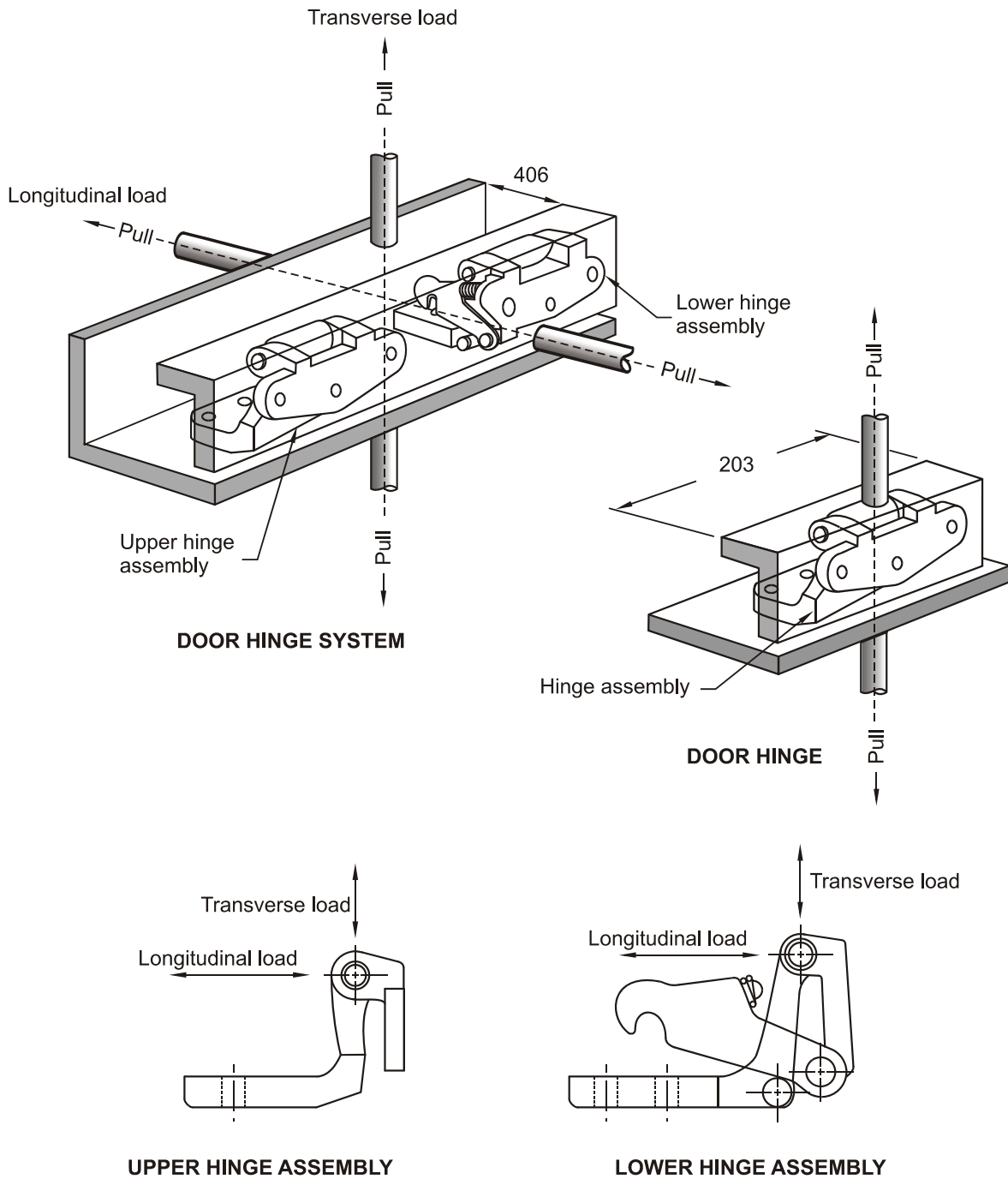

Figure 6 — Acceleration Pulse



Notes:
X = Longitudinal direction
Y = Transverse direction
Z = Vertical direction

Figure 7 — Vehicle Coordinate Reference System for Inertial Testing



- Notes:
 1. Dimensions in mm
 2. Not to scale

Figure 8 — Hinge Static Test Fixtures

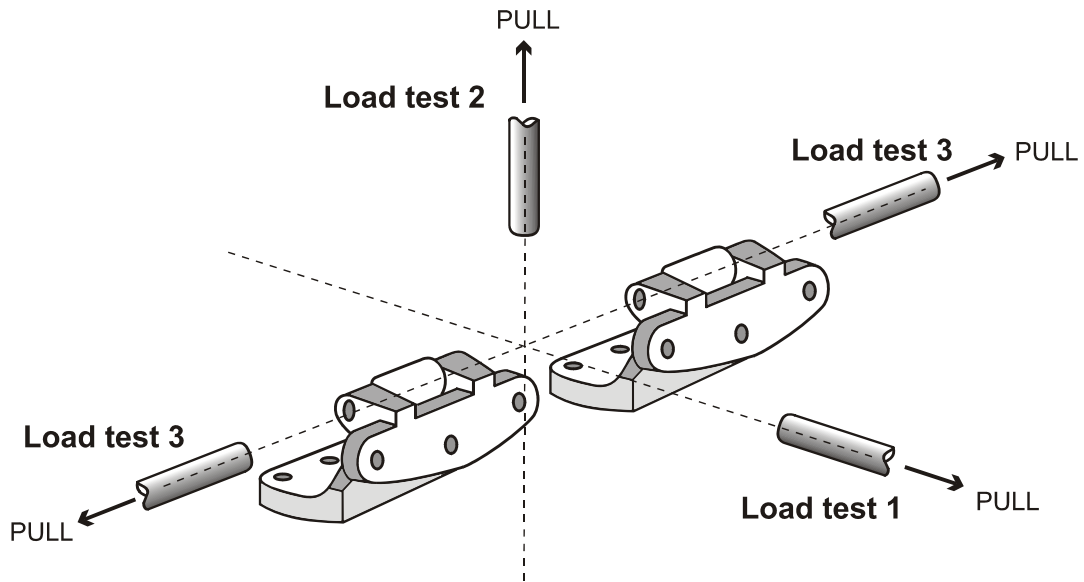

Note: Load test three is only for back doors that open upward.

Figure 9 — Hinge Static Test Load Directions for Back Doors

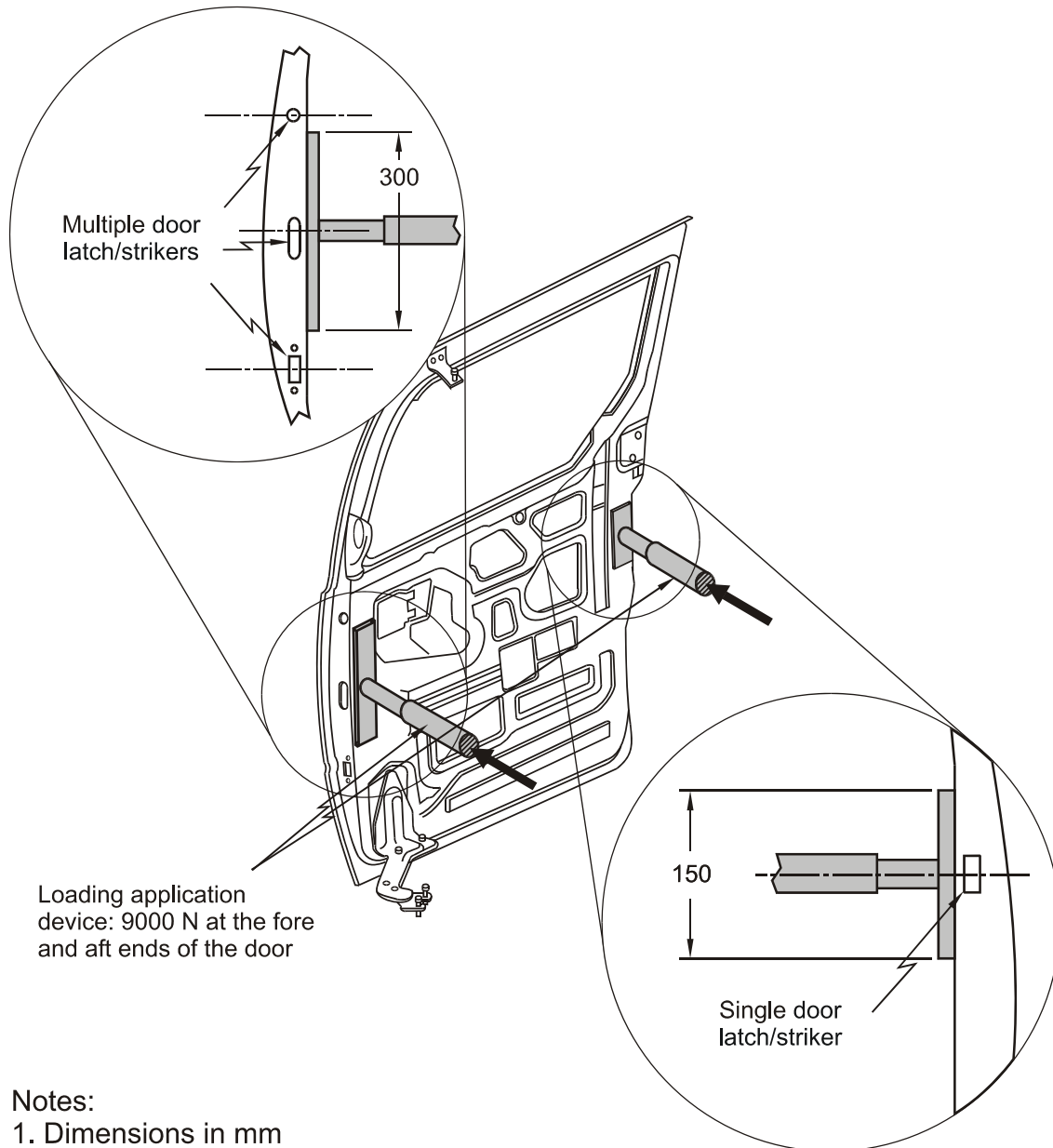

Notes:

1. Dimensions in mm
2. Not to scale
3. Sliding door is shown separate from the vehicle.

Figure 10 — Sliding Side Door Full-Vehicle Test Procedure